

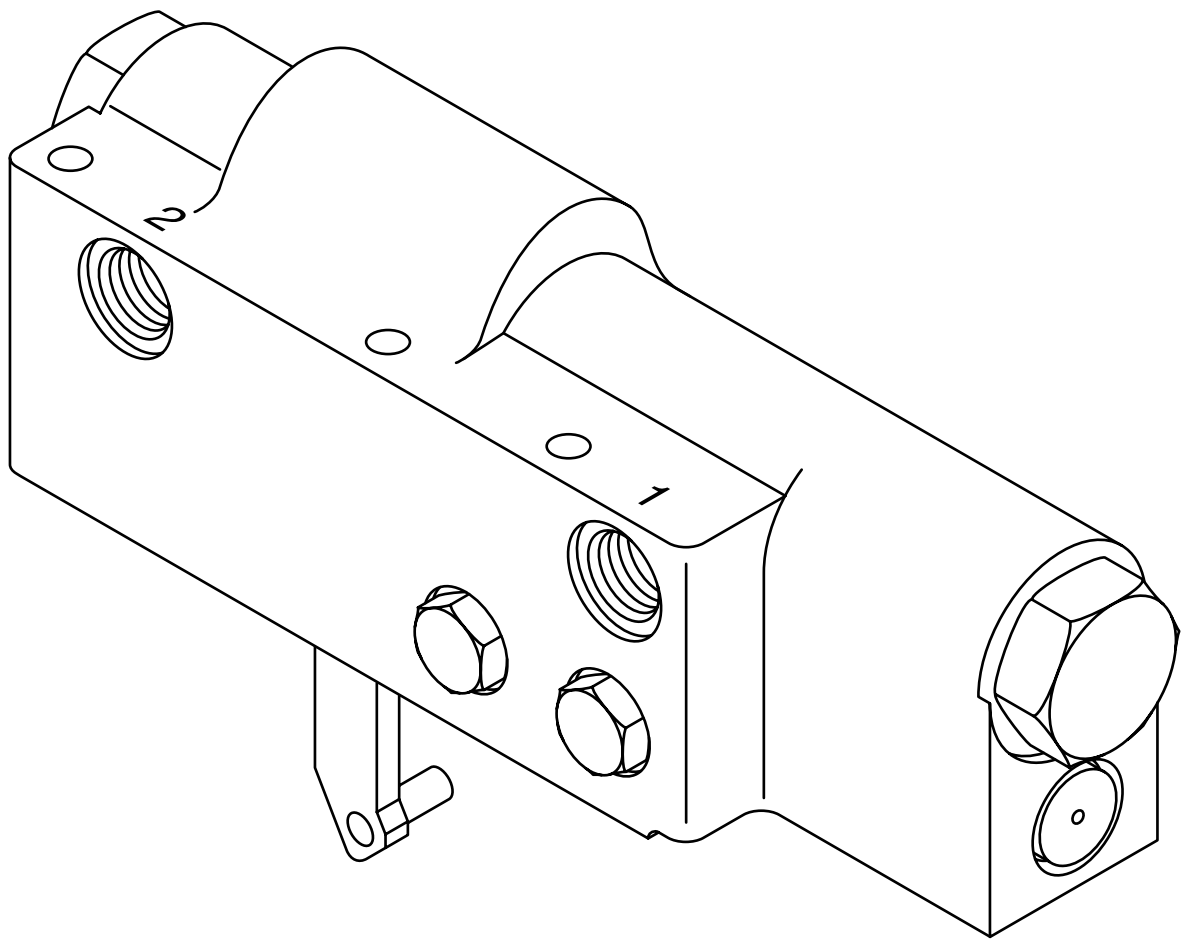

## Repair Information



## Hydraulic Remote Controller

# Parts Drawing

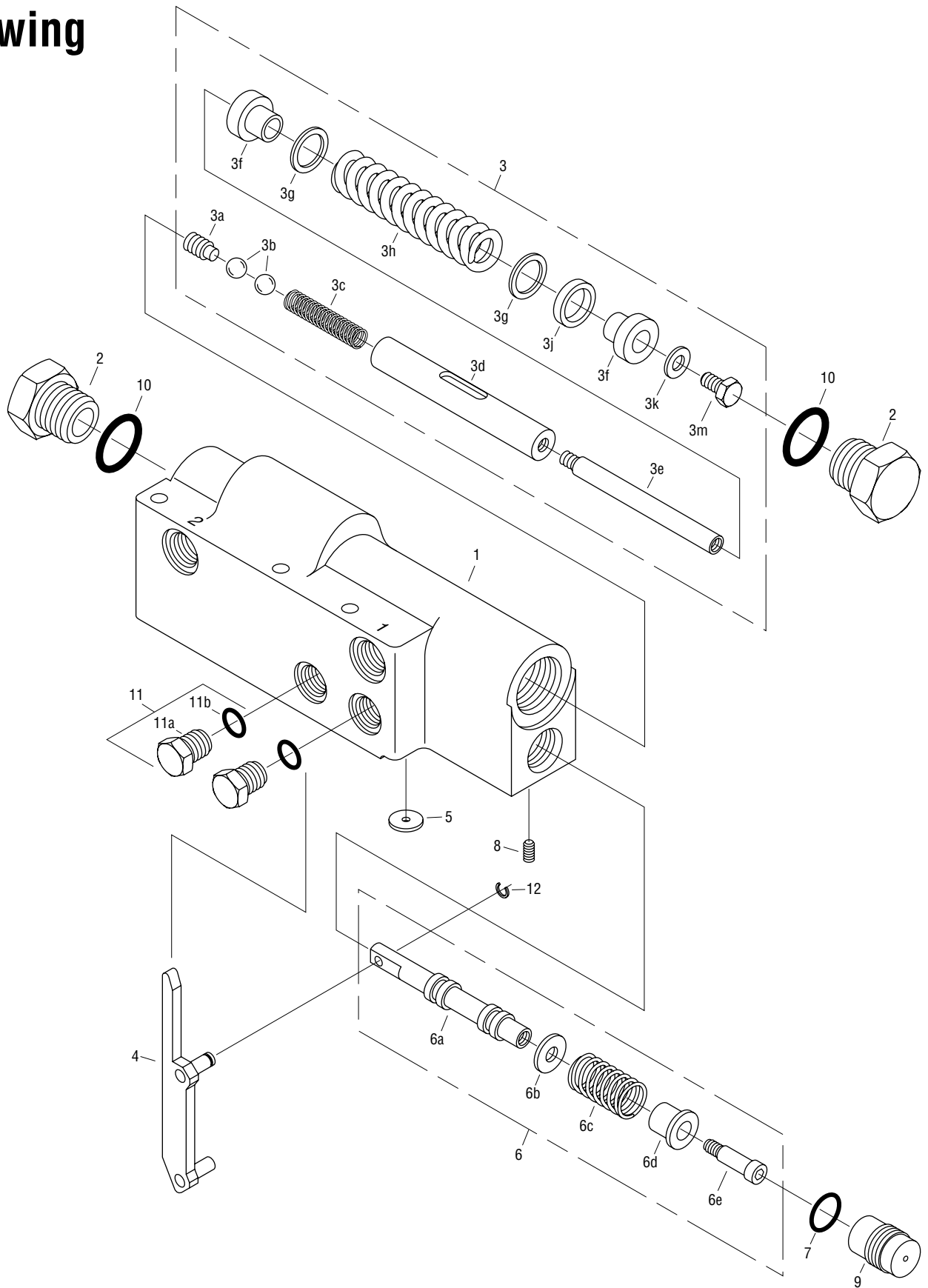

## Disassembly

Cleanliness is extremely important when repairing hydraulic controls. Work in a clean area.

**Note:** The numbers in ( ) correspond to the numbers in the parts drawing.

1. Remove the retaining ring (12) and the connecting link (4).
2. Remove the two o-ring/plug assemblies (11).
3. Remove the two plugs (2) and o-rings (10) and slide the control piston subassembly (3) from the body (1).

**Note:** Disassembly of the control piston subassembly (3) is not recommended. The threads at both ends of the bushing rod (3e) are Loctited. If disassembly is necessary, you may apply heat to weaken the Loctite.

4. Loosen the set screw (8) 1 or 2 turns then unscrew the spring box adjustment screw (9). Remove o-ring (7).
5. Slide the control spool subassembly (6) from the body (1).

**Note:** Disassembly of the control spool subassembly (6) is not recommended. The threads are Loctited. If disassembly is necessary, you may apply heat to weaken the Loctite.

**Note:** Do not remove the orifice (5) unless it is damaged or its size is to be changed. To remove the orifice, strike it in the center with a center punch. This will curl the orifice allowing it to be removed.

**Important:** Do not flatten and reuse orifices.

Install a new orifice and stake it 3 times, with a center punch, to hold it in place.

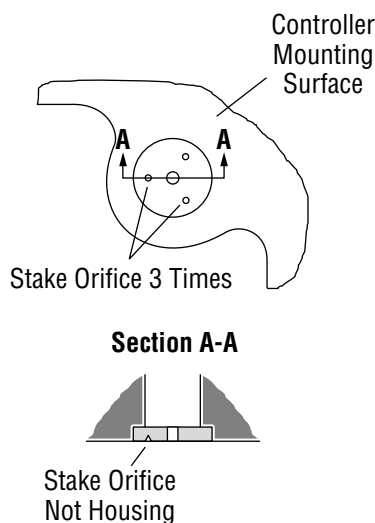

## Reassembly

Wash all parts in clean solvent and blow them dry with filtered compressed air. Do not wipe parts dry with cloth or paper towels, lint in a hydraulic system will cause damage.

Replace all o-rings. Lubricate them before installation.

6. If the control piston subassembly (3) was taken apart, reassemble it. Install the same thickness of bushing washers (3g) and spacer (3j). Replace any worn parts.

**Note:** The spacer (3j) is not used on all control piston subassemblies.

7. Apply Loctite 271, per the manufacturer's instructions, to the threads at both ends of the bushing rod (3e) and tighten them to 10.3 - 12.4 Nm [91 - 110 lb-in].

**Important:** Do not apply Loctite to the set screw (3a).

8. Apply a coating of clean hydraulic fluid to the control piston subassembly (3) and slide it into the body (1).

9. Install plugs (2) use new o-rings (10) and tighten them to 133 - 160 Nm [98 - 118 lb-ft].

10. If the control spool subassembly was taken apart, reassemble it. Apply Loctite 271, per the manufacturer's instructions, to the threads of the shoulder screw (6e) and tighten it to 3.7 - 4.5 Nm [33 - 40 lb-in].

11. Apply a coating of clean hydraulic fluid to the control spool subassembly (6) and slide it into the body (1).

12. Install the spring box adjustment screw (9) with a new o-ring (7). Screw it in until the control spool subassembly (6) end play is .000 to .025 mm [.000 to .001 in].

13. Tighten set screw (8) to 3.7 - 4.5 Nm [33 - 40 lb-in].

14. Install the control link (4) by slipping it between the two balls (3b) and securing it with retaining ring (12). The link should be perpendicular to the mounting surface.

## WARNING

Personal injury or death may result if an out of neutral adjustment condition exists. See the back page of this document for neutral adjustment procedure.

# WARNING

After the controller has been repaired and reinstalled on the pump, it may be necessary to adjust the controller so pump output is zero when no control pressure is applied.

When a repaired controller is installed on a vehicle steps must be taken to assure that no injury or damage results if the vehicle moves due to the pump not being in neutral. Eaton suggests jacking the vehicle off the ground and watching for wheel rotation indicating an out of neutral adjustment condition.

## Neutral Adjustment Procedure

With the pump operating with 13.79 bar [200 PSI] charge pressure and zero pilot control pressure, remove the plug (2) from the shaft end of the controller. Using a hex key turn the set screw (3a) until pump output is zero. Take care not to push or pull the control piston when making the adjustment. Next, turn the set screw (3a) until the unit just starts to go into stroke in one direction. Then, count the turns to get it to just stroke in the other, 2 to 4, and set the set screw (3a) half way in between. Install plug (2) and o-ring (10) tighten it to 133 - 160 Nm [98 - 118 lb-ft].

Eaton Corporation  
**Hydraulics Division**  
15151 Hwy. 5  
Eden Prairie, MN 55344  
Telephone 612/937-9800  
Fax 612/937-7130

Eaton Ltd.  
**Hydraulics Division**  
Glenrothes, Fife  
Scotland, KY7 4NW  
Telephone 01-592-771-771  
Fax 01-592-773-184

Eaton GmbH  
**Hydraulics Products**  
Am Schimmersfeld 7  
40880 Ratingen, Germany  
Telephone 02102-406-830  
Fax 02102-406-800



**Quality System Certified**  
Products in this catalog are manufactured  
in an ISO-9001-certified site.

<http://www.eaton.com>

Form No. 7-417 October, 1993

Copyright Eaton Corporation, 1993  
All Rights Reserved  
Printed in USA

# EATON