

Vickers®

Piston Motors



Inline Piston Motors

Fixed and Variable Displacement

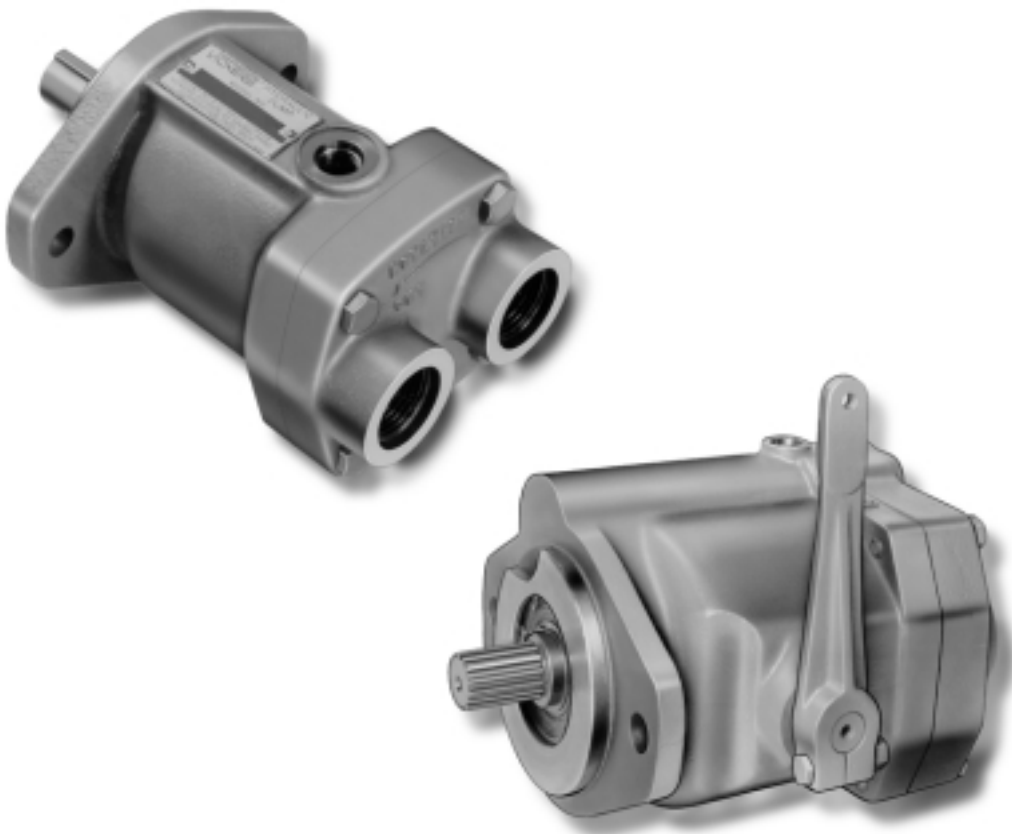

VICKERS

Revised 5/99

Table of Contents

Introduction	3
Fixed Displacement Motors	
MFB Model Series	
Ratings	4
Model Code	4
MFB5 Model Series	
Performance Characteristics	5
Installation Dimensions	6
MFB10 Model Series	
Performance Characteristics	7
Installation Dimensions	8
MFB20/29 Model Series	
Performance Characteristics	9
Installation Dimensions	10
MFB45 Model Series	
Performance Characteristics	11
Installation Dimensions	12
MFE15/19 Model Series	
Ratings	13
Model Code	13
Installation Dimensions	14
Variable Displacement Motors	
MVB Model Series	
Ratings	15
Model Code	15
MVB5 Model Series	
Performance Characteristics	16
Installation Dimensions	17
MVB10 Model Series	
Performance Characteristics	18
Installation Dimensions	19
MVE19 Model Series	
Ratings	20
Model Code	20
Installation Dimensions (control pintle and side ports)	21
Installation Dimensions (pilot control and side ports)	22
Installation Dimensions (control pintle and end ports)	23
Installation Dimensions (pilot control and end ports)	24
Foot Mounting Bracket	25
Application and Service Information	26

Introduction

General Data

These motors are of axial piston, fixed or variable displacement, inline design. The units can be operated in either direction of rotation. Flow direction is as indicated.

MFB motors are variable horsepower – horsepower being approximately proportional to rpm with a given constant operating pressure. Service may be continuous, intermittent, continuous reversing, or stalled without damage when properly protected by a relief valve.

Output speeds are dependent on input flow. Speed ranges of at least 36:1 are possible at the maximum torque rating by varying flow to the motor.

Fixed Displacement Inline Piston Motors (MFB)

Vickers fixed displacement inline piston motors offer a choice of five torque ratings, speed from 100 to 3600 r/min and pressures to 210 bar (3000 psi). Reversible shaft rotation and flange or foot mountings are available.

• High Efficiency

Overall operating efficiency can be as high as 93% and volumetric efficiency as high as 97%, depending on motor size, pressure, speed, fluid viscosity, and temperature.

• Compact, High Performance

High speeds, pressures and efficiencies give Vickers inline piston motors power density. The result is high performance in a compact package that requires minimum installation space.

• Rotation

Rotation can be reversed simply by reversing the direction of flow through the motor ports.

• Low Speed Capability

Minimum speed can vary between 50 and 100 r/min, depending upon motor size and characteristics of the drive load.

• Reliability

Vickers inline design has seen countless hours of rugged service on a variety of machinery applications. This proven design has provided significant cost and weight savings, while taking full advantage of the high efficiency inherent in piston units.

• Serviceability

The simplicity of Vickers design not only permits easy servicing (often without removing the unit), and also increased reliability. Vickers inline motors have fewer parts compared to competitive units.

Variable Displacement Inline Piston Motors (MVB, MVE)

Vickers variable displacement inline piston motors offer a variety of displacements, speeds, and pressures.

• Rotation

Shaft rotation can be reversed simply by reversing the direction of flow through the motor ports. However, shaft rotation must not be reversed by reversing the motor's displacement control, while the motor is running.

• Controls

A handwheel or lever is used to select displacement. Both controls allow the motor to operate on either side of center, permitting bi-directional shaft rotation. The controls can be assembled on either side of the motor to facilitate motor installation and provide optimum control accessibility.

• Speed Ranges

Output speeds are dependent on input flow and the position of the displacement control. With constant placement to the MVB5 or MVB10 motor, a speed range of 4:1 is possible by varying displacement.

By varying flow to the MVB5 speed ranges of 12:1 (300 to 3600 r/min) and higher are possible with output torques to approximately 31 Nm (270 lb. in.)

By varying flow to the MVB10, speed ranges of 11:1 (300 to 3200 r/min) and higher are possible with output torques to approximately 61 Nm (540 lb.in.)

Both the MVB5 and the MVB10 motor will operate at speeds as low as 50 r/min with appropriate circuit and application considerations.

Application

Vickers piston motors are designed to meet the specifications shown in the "Ratings" section of this catalog. To ensure maximum performance in conjunction with your specific application, consult your Vickers sales representative if your:

- Pressure requirements are above 100 bar (1500 psi).
- Speed is above 1800 r/min rating.
- Speed is below minimum recommended speed of 100 r/min.
- System requires fire resistant or other fluids.
- Operating temperature is not within the range of 38° to 66° C (100° to 150° F). With proper application and fluid consideration, a greater temperature range is permissible.
- Oil viscosities at operating conditions is not within 100 to 250 SUS.
- Application requires an indirect drive.
- Oil viscosity at start-up is in excess of 1000 SUS.
- Mounting attitude is other than horizontal.

Installation Data

Horizontal mounting is recommended to maintain the necessary case fluid level. The case drain line must be full size and unrestricted, and connected from the uppermost drain port directly to the reservoir in such a manner that the housing remains filled with fluid. The piping of the drain line must prevent siphoning. The drain line should be piped so that it terminates below the reservoir fluid level. No other lines are to be connected to the drain line. Caution must be exercised to never exceed 0,35 bar (5 psi) unit case pressure.

Starting

Before starting, fill case with system fluid through the uppermost drain port. Housing must be kept full at all times to provide internal lubrication.

MFB Model Series

Model Code

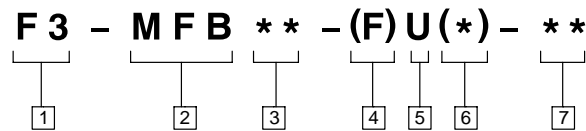

1 Special Seals

F3 – Seals for use with mineral oil or fire resistant fluids.
Blank – Omit if not required

2 Model Series

M – Motor
F – Fixed displacement
B – Inline type

3 GPM Rating @ 1800 rpm

5 – 19 L/min (5 USgpm)
10 – 37,9 L/min (10 USgpm)
20 – 75,7 L/min (20 USgpm)
29 – 109,8 L/min (29 USgpm)
45 – 170,3 L/min (45 USgpm)

4 Mounting Type

F – Foot bracket
(For separate foot bracket kit, order model model FB–A–10)
Blank – Omit for flange mounting

5 Rotation

U – Either direction

6 Shaft End (MFB5/10 only)

Y – Standard Shaft
Blank – Optional shaft

* Optional shaft is available only to provide interchangeability with earlier (–10 design) units. (Not recommended for operation above 1800 r/min and 100 bar (1500 psi).

6 Port Connections (MFB 45)

F – SAE 4-bolt Flanged Ports

7 Design Number

Subject to change

21 – 21 Design (MFB5)
31 – 31 Design (MFB10)
10 – 10 Design (MFB 20, 29, 45)

Specifications

Model	Theoretical Displ. cm ³ /rev (in ³ /rev)	Flow L/min (USgpm) @ Rated r/min	Operating Speed r/min		Pressure bar (psi)		Output Torque Nm (lb in)		Dry Weight kg (lb)
			Rated	Max	Rated	Max	Rated	Max	
MFB5	10,5 (0.643)	19,0 (5.0)	1800	3600	100 (1500)	210 (3000)	15,25 (135)	30,5 (270)	5,0 (11)
MFB10	21,12 (1.29)	37,9 (10.0)	1800	3200	100 (1500)	210 (3000)	32,1 (284)	64,2 (568)	9,5 (21)
MFB20	42,8 (2.61)	75,7 (20)	1800	2400	100 (1500)	175 (2500)	50,85 (450)	101,7 (900)	18,5 (49)
MFB29	61,6 (3.76)	109,8 (29)	1800	2400	70 (1000)	140 (2000)	58,75 (520)	117,5 (1040)	18,5 (49)
MFB45	94,4 (5.76)	170,3 (45)	1800	2200	100 (1500)	210 (3000)	135,6 (1200)	271,2 (2400)	33 (73)

MFB5 Model Series

Performance Characteristics

Based on oil temperature of 49°C (120°F) – Atmospheric Outlet

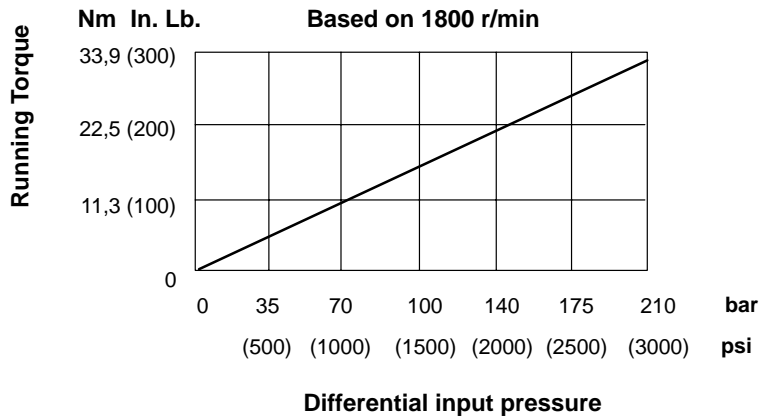
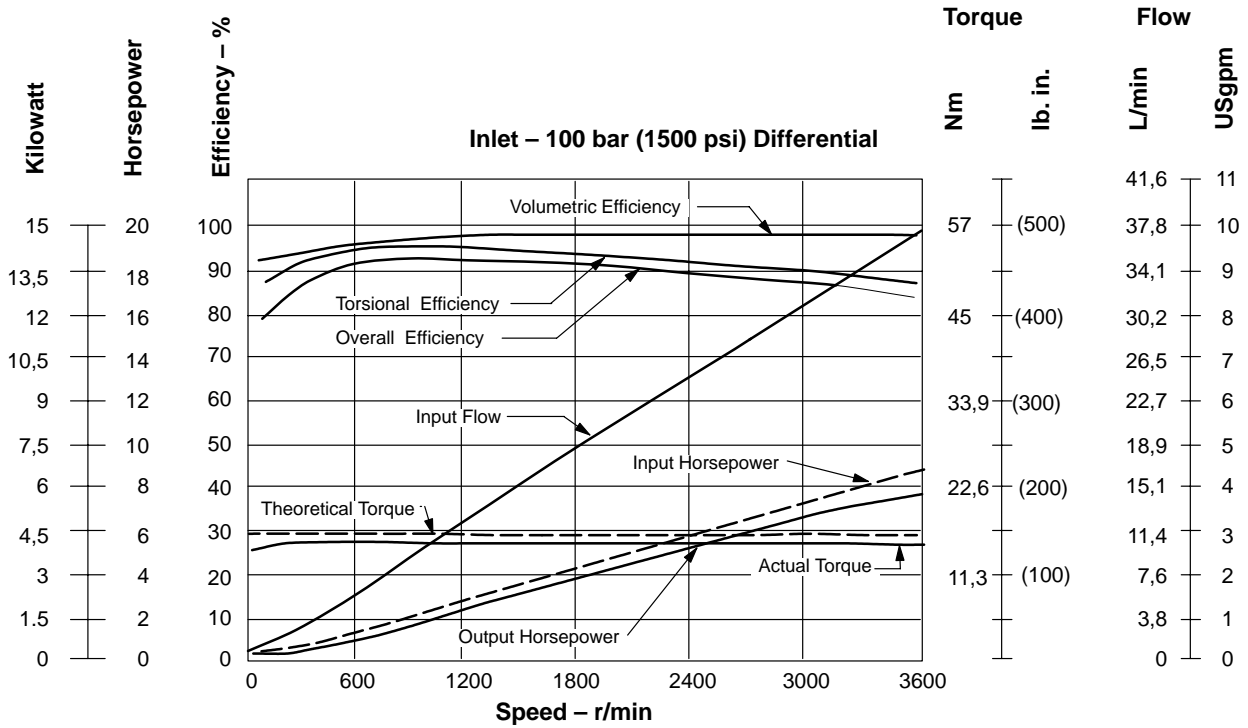

Installation Dimensions

Millimeters (inches)

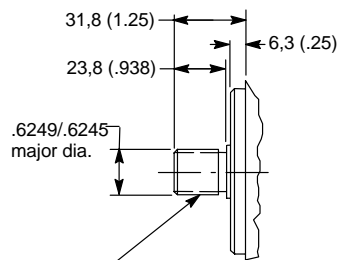
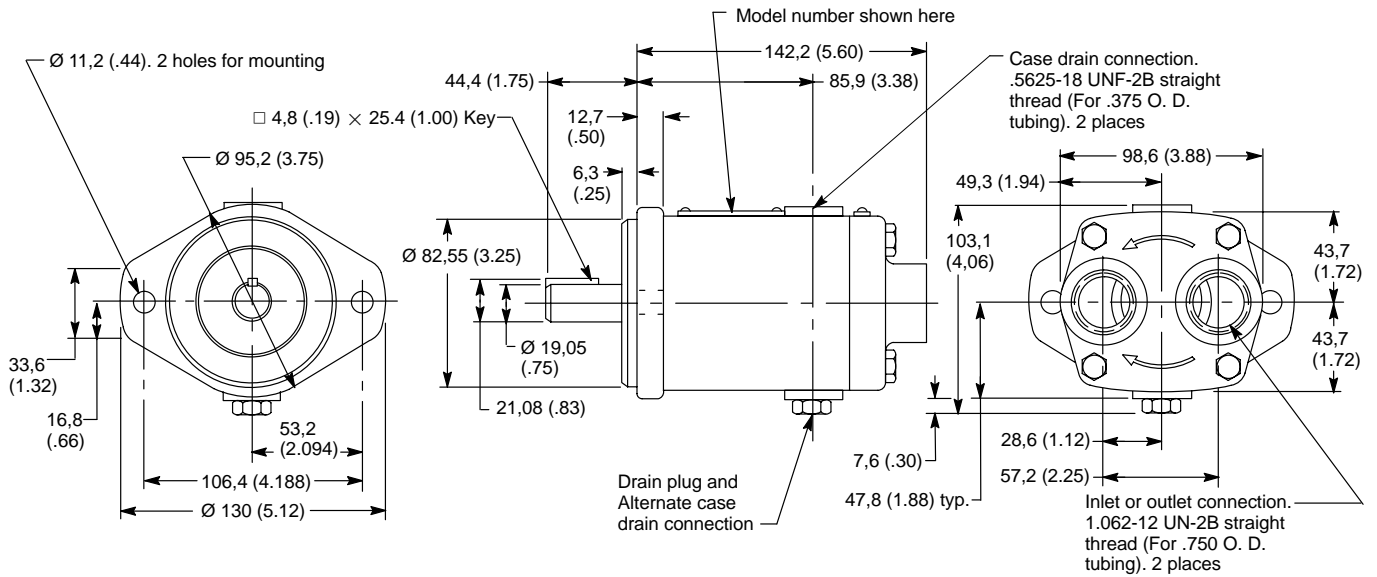

Optional drive shaft.
 SAE standard involute spline.
 Flat root major diameter fit.
 9 teeth 16/32 pitch.
 .5625 pitch diameter ref.
 .4835/.4725 minor diameter

MFB10 Model Series

Performance Characteristics

Based on oil temperature of 49° C (120° F), 20.6 cSt (100 SUS) and atmospheric outlet

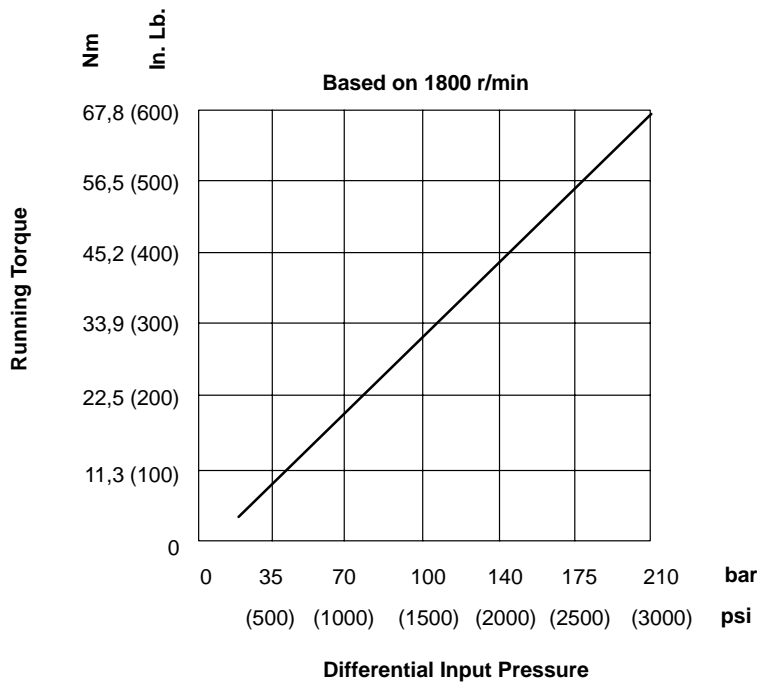
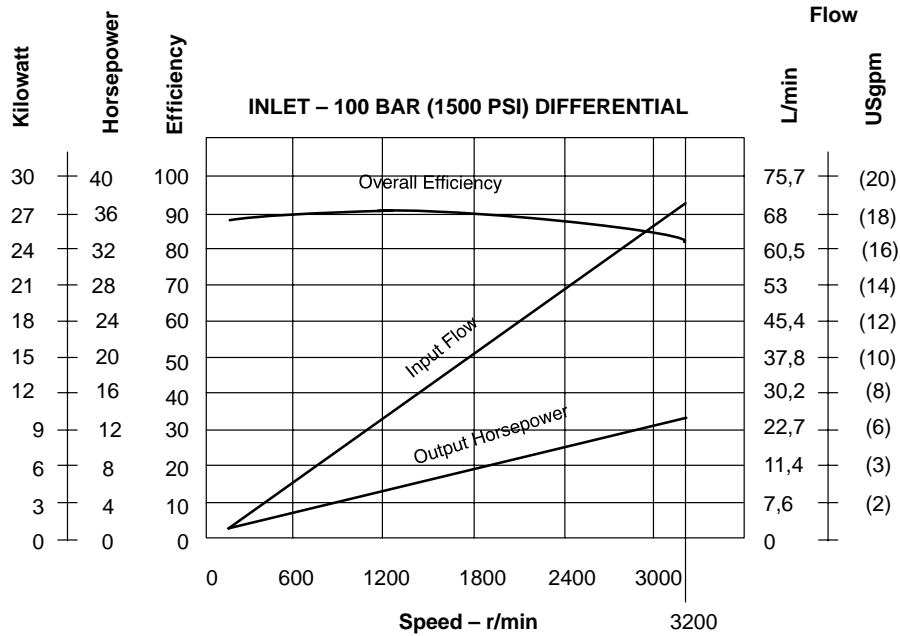

Installation Dimensions

Millimeters (inches)

Shaft Type	A	B	C
Std. (Code Y)	58,7 (2.31)	228,1 (8.98)	47,6 (1.874)
Short	44,4 (1.75)	213,9 (8.42)	33,3 (1.312)

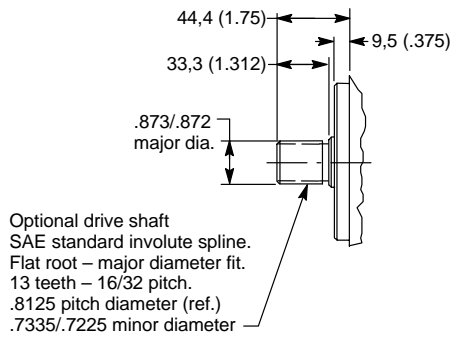
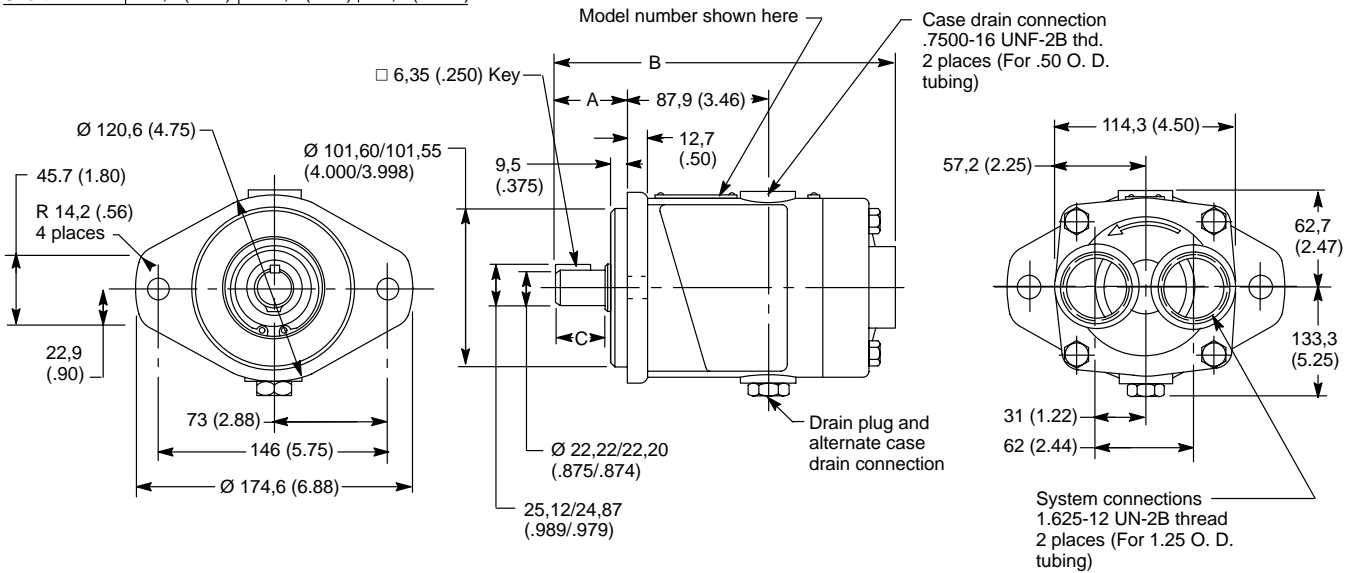

MFB20 & MFB29 Model Series

Performance Characteristics

Based on oil temperature of 49°C (120°F), 20.6 cSt (100 SUS)

X indicates minimum speed with approx. ± 10% speed variation

O indicates stall torque

MFB20

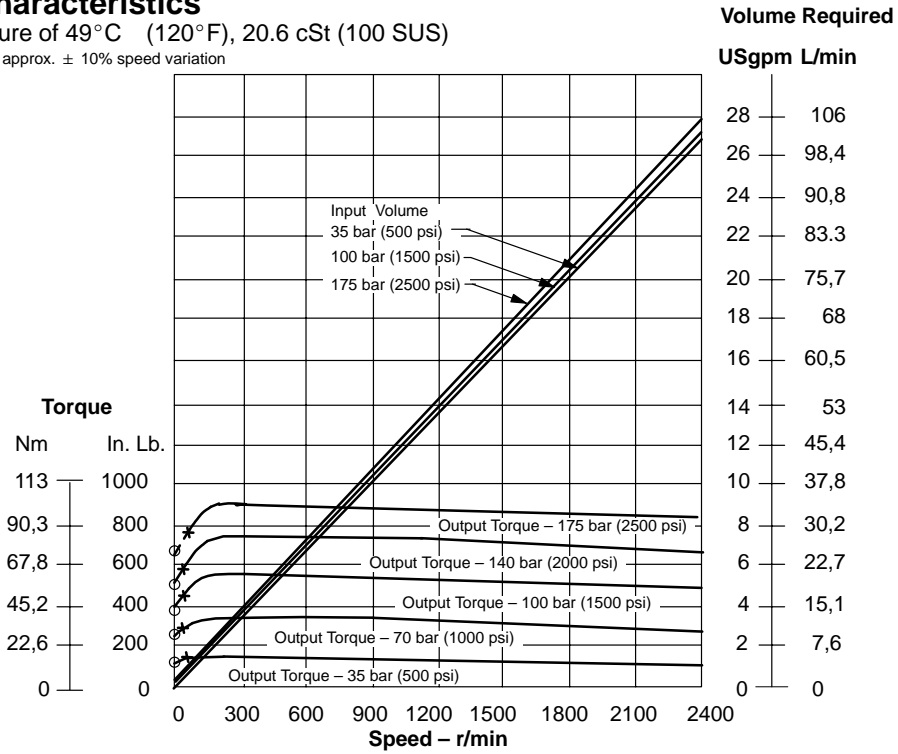

MFB29

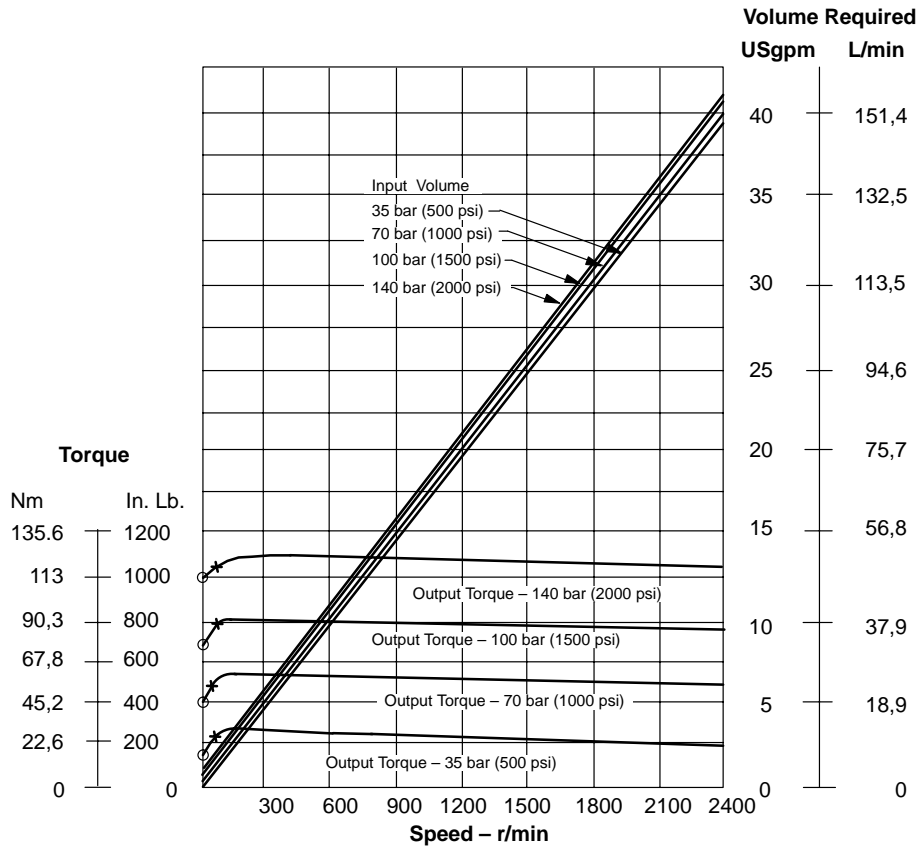

Installation Dimensions

Millimeters (inches)

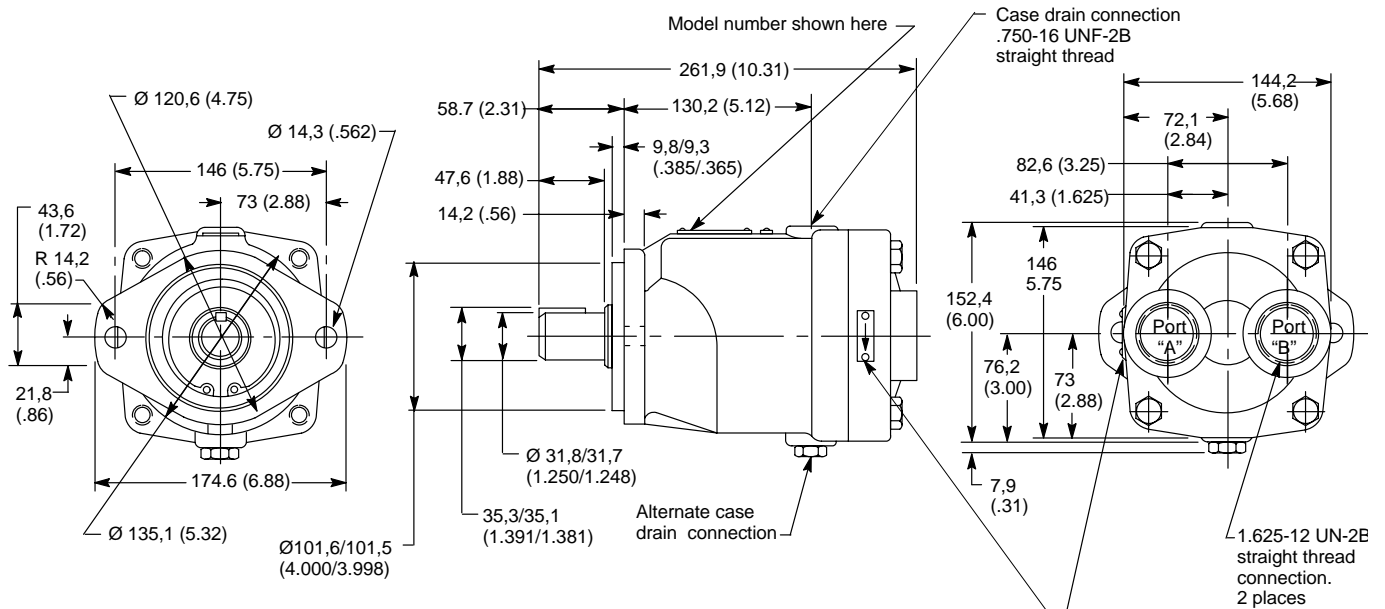

Shaft Rotation	Outlet Port
Right hand	"A"
Left hand	"B"

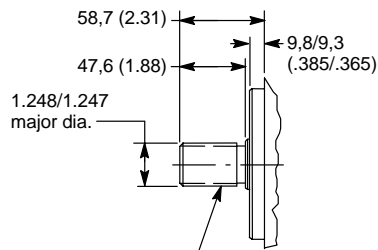

Optional drive shaft
SAE standard involute spline.
Flat root – major diameter fit.
14 teeth – 12/24 pitch.
1.1667 pitch diameter (ref.)
1.0627/1.0497 minor diameter

MFB45 Model Series

Performance Characteristics

Based on oil temperature of 49° C (120° F), 20.6 cSt (100 SUS)

X indicates minimum speed with approximate $\pm 10\%$ speed variation
 O indicates stall torque

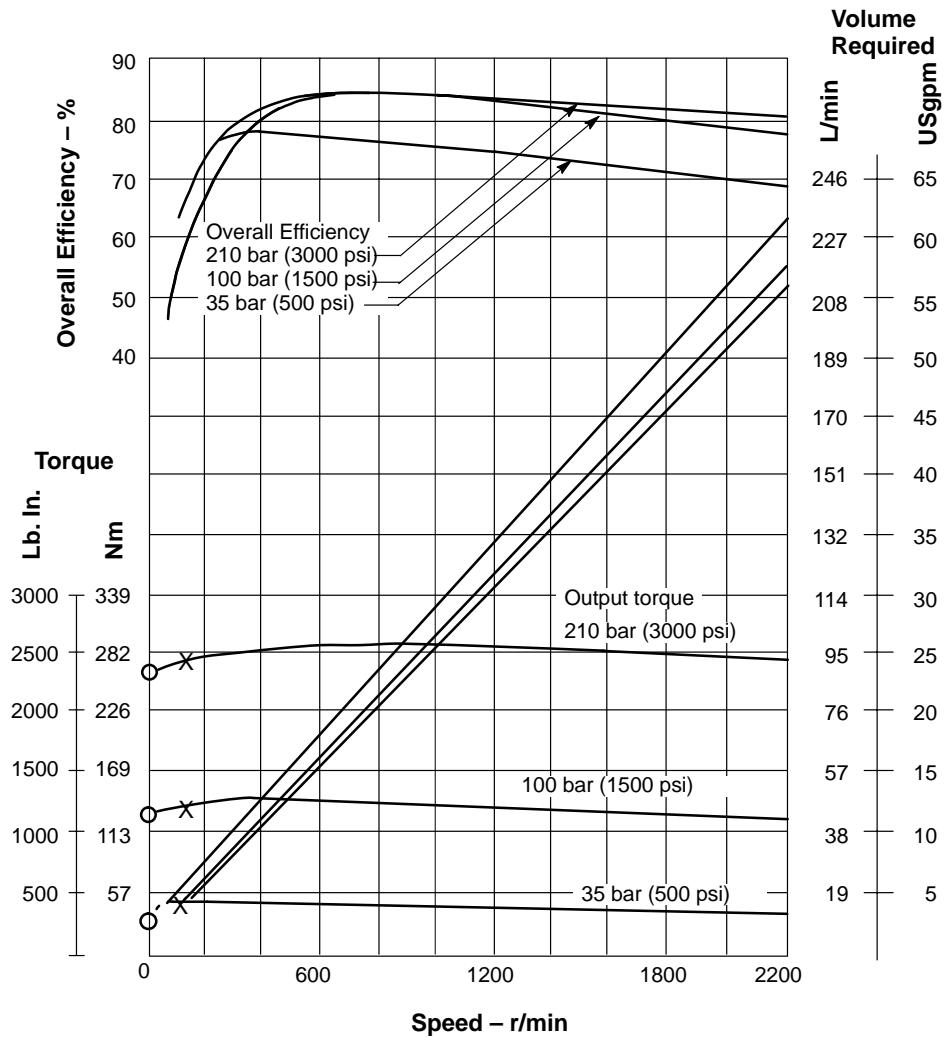

Installation Dimensions

Millimeters (inches)

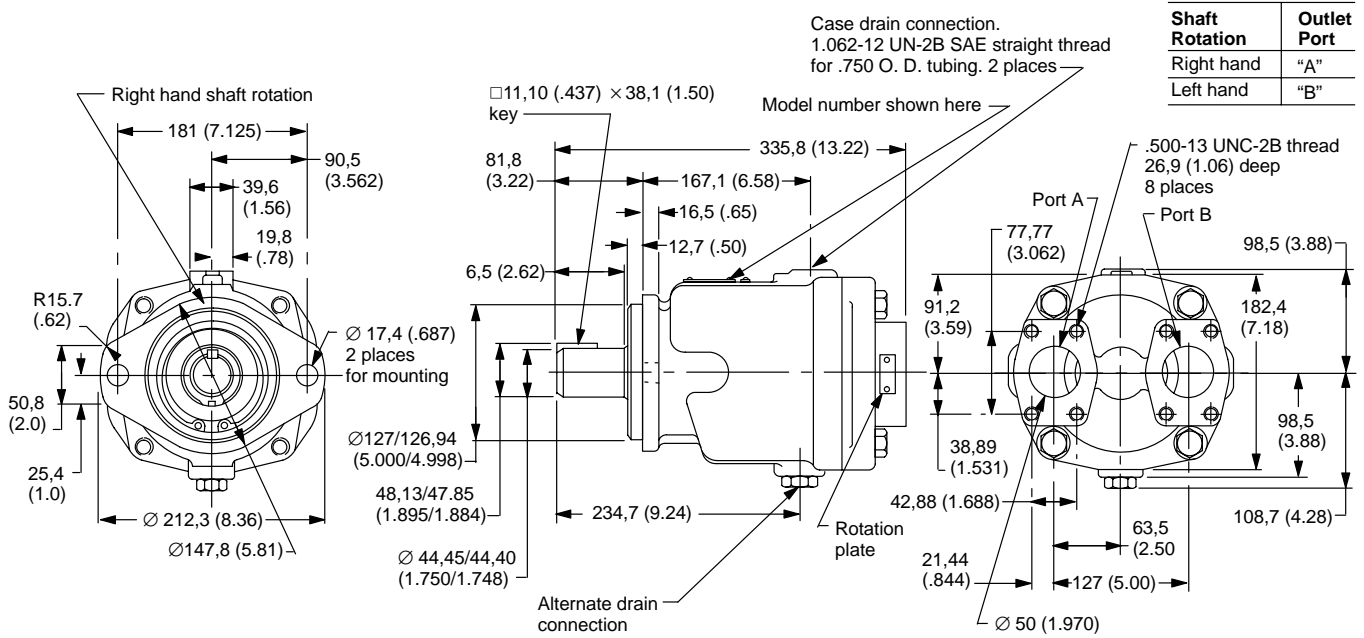

MFE15 and MFE19 Model Series

Ratings

Theoretical Maximum Displacement	Maximum Rated Input Speed	Maximum Rated Output Speed	Maximum Intermittent Pressure	Maximum Continuous Pressure	Rated Power
MFE15 33 cm ³ /rev (2 in ³ /rev)	3600 r/min	3600 r/min	350 bar (5000 psi)	210 bar (3000 psi)	16,8 kW per 1000 r/min (22.5 hp per 1000 r/min)
MFE19 41 cm ³ /rev (2.5 in ³ /rev)					

Model Code

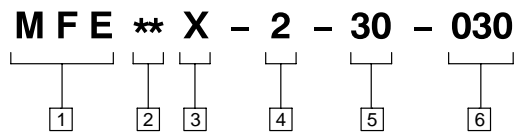

1 Model Series

MFE – Fixed displacement piston motor

2 Rated Flow

15 – 57 L/min (15 USgpm)
 19 – 72 L/min (19 USgpm)

3 Thru Shaft

X – Available only on side ported models. Omit if not required

4 Output Shaft *

2 – SAE B-B splined

* Other shafts available. Contact your Vickers sales engineer.

5 Design Number

30 – Subject to change. Installation dimensions remain the same for design number 30 through 39

6 Special Suffix

Blank – Side Ports
 030 – End Ports

Installation Dimensions

Millimeters (inches)

SAE B-B Splined Shaft		
External Involute Spline		
* Modified	ANS B92.1 – 1970	
0.9375 Pitch Dia.	.8119 Base Dia.	
Flat root class 5 side fit		
15 teeth 16/32 pitch 30° Pr. Angle		
Major Diameter	Form Dia.	Minor Diameter
.9835 Max. .9780 Min	0.872	— Max. .840 Min

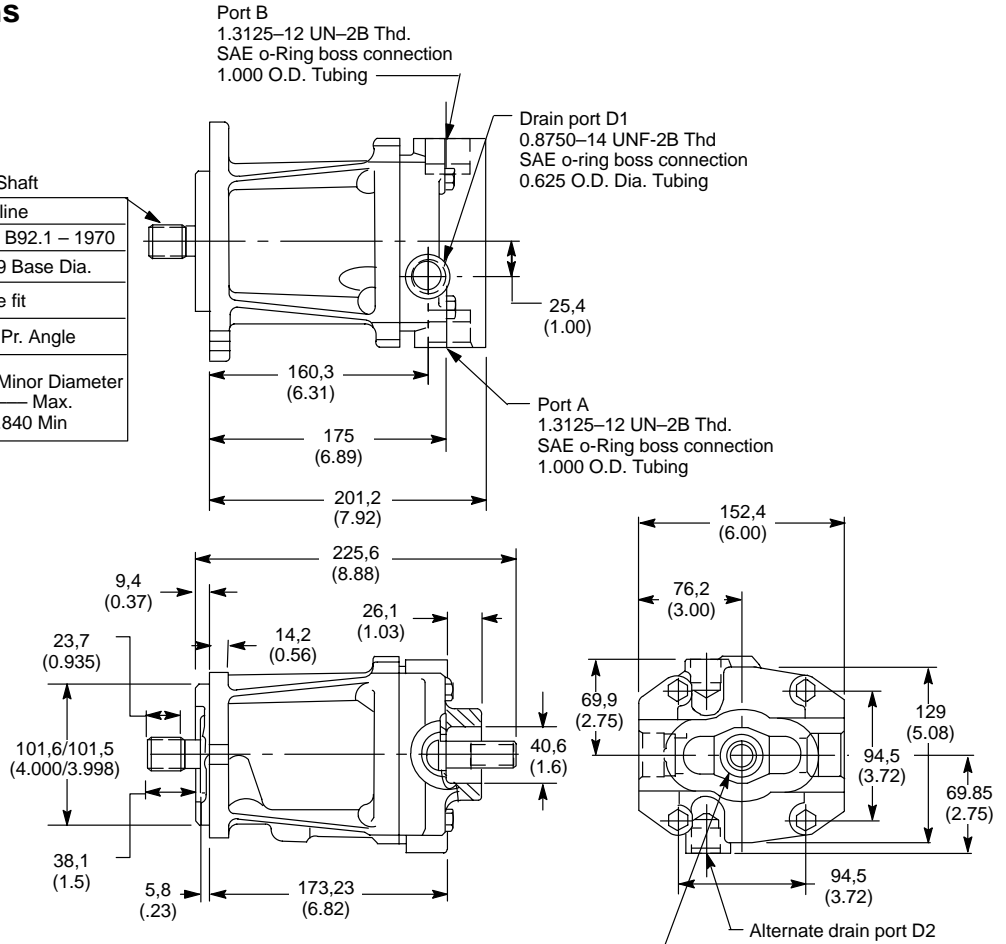
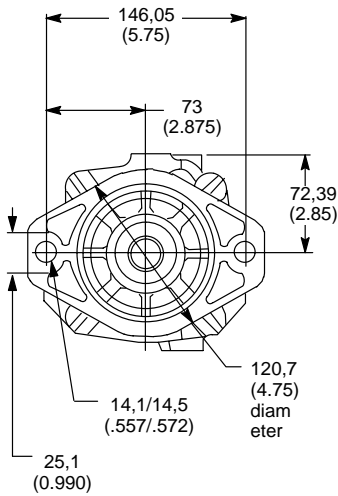

Optional Thru Shaft		
External Involute Spline		
ASA B5.15 – 1960		
.7813 Pitch Dia.	.6766 Pitch Dia.	
25 teeth 32/64 pitch 30° Pr. Angle		
Major Dia.	Form Dia.	Minor Dia.
203,4 (.8022) Max 20,3 (.7992) Min	18,9 (.7460)	18,8 (.7398) Max. 18,6 (.7318) Min

Thru shaft extension is limited to a maximum torque of 327 Nm (2900 in. lbs.) with no overhung load. Applications subjecting shaft extension to both bending and torsional loads are subject to Vickers engineering approval.

END-PORTED MODEL

See side-ported model above for additional dimensions.

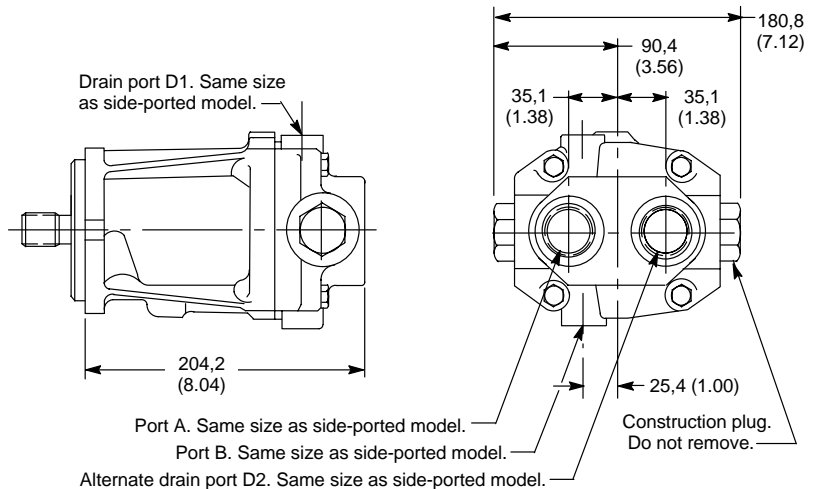

Port A. Same size as side-ported model.
 Port B. Same size as side-ported model.
 Alternate drain port D2. Same size as side-ported model.
 Construction plug. Do not remove.

MVB5 and MVB10 Model Series

Ratings

Model	Theoretical Displacement cm ³ /rev (in ³ /rev)	Flow L/min (USgpm) @		Operating Speed (r/min)		Pressure bar (psi)		Output Torque Nm (lb. in.)	
		1800 r/min	3600 r/min	Rated	Max	Rated	Max	Rated	Max
MVB5	10,5 (0.643)	19,0 (5.0)	38,0 (10)	1800	3600	100 (1500)	210 (3000)	15,25 (135)	30,5 (270)
MVB10	21,12 (1.29)	37,9 (10.0)	68,1 (18.0)	1800	3200	100 (1500)	210 (3000)	30,5 (270)	61,0 (540)

Model Code

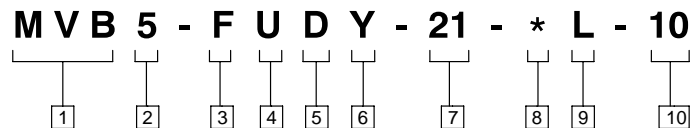

1 Model Series

M – Motor
V – Variable displacement
B – Inline type

2 USgpm Rating @ 1800 rpm

5 – 5 USgpm

3 Mounting Type

F – Foot bracket
(For separate foot bracket kit, order model model FB-A-10)
Blank – Omit for flange mounting

4 Rotation

U – Either direction

5 Displacement

D – Both sides of center

6 Shaft Type

Y – Keyed, standard 1.75 extension,
0.759 diameter

7 Motor Design Number

Subject to change

8 Control Type

H – Handwheel
M – Lever

9 Control Position

L – Left hand
Blank – Right hand

10 Control Design Number

Subject to change

MVB5 Model Series

Performance Characteristics

Based on oil temperature of 49° C (120° F), 20.6 cSt (100 SUS) and atmospheric outlet

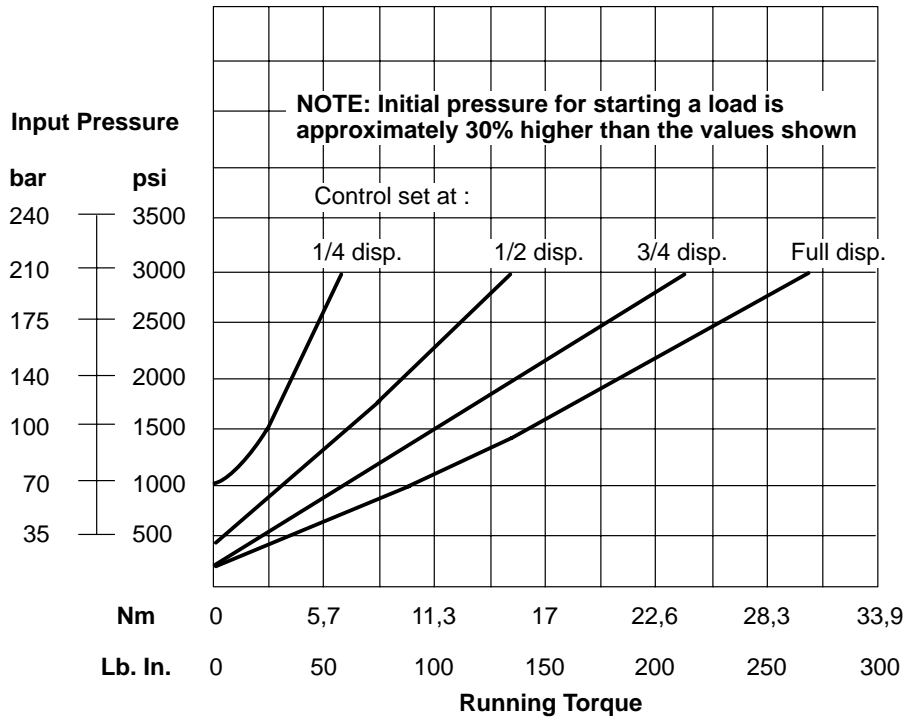
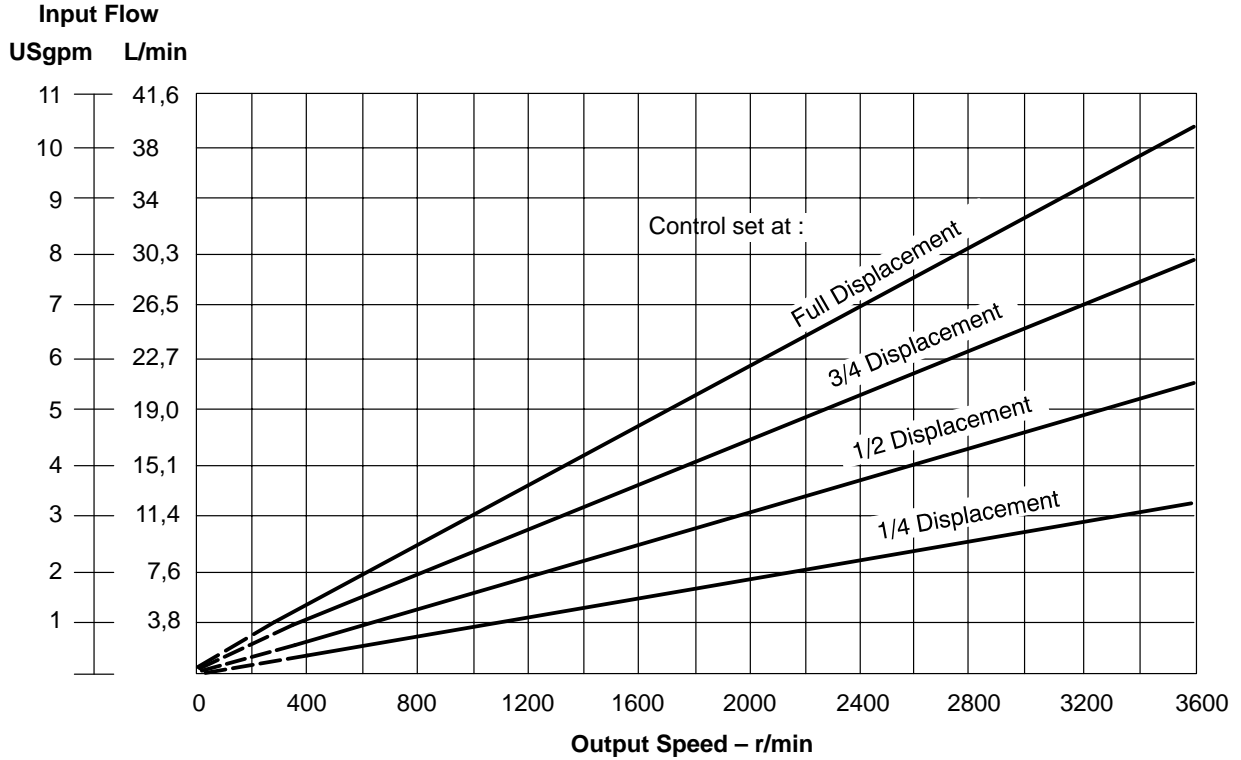

MVB5 Model Series with Handwheel or Lever Control

Installation Dimensions

Millimeters (inches)

Handwheel Control

Provides manual selection of motor displacement. Handwheel controlled units may be operated on either side of center permitting bi-directional output rotation.

Shaft Rotation	Pointer Position	Handwheel Rotation from Zero	Inlet Port
R.H.	1	Clockwise	B
R.H.	2	Counter-clockwise	A
L.H.	1	Clockwise	A
L.H.	2	Counter-clockwise	B

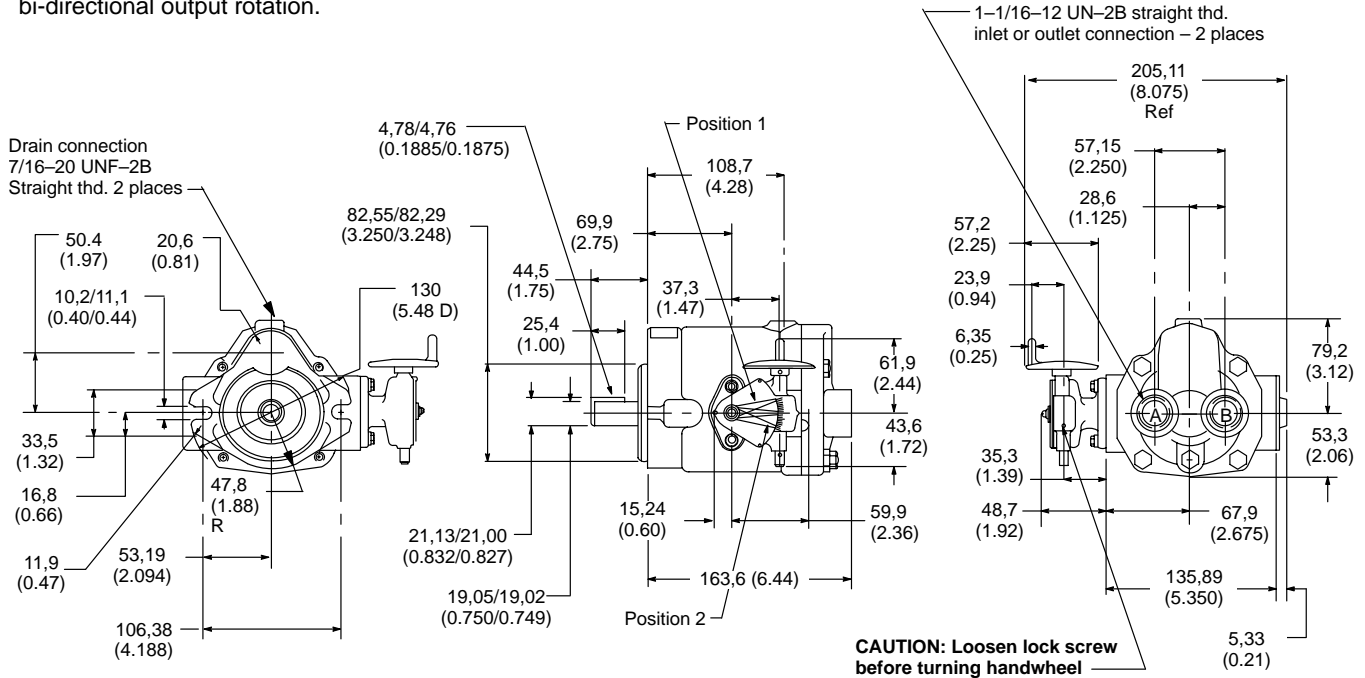

Lever Control

Provides mechanical or manual selection of motor displacement. Lever controlled units may be operated on either side of center permitting bi-directional output rotational characteristics. Lever controls must be secured by a suitable linkage arrangement to maintain desired setting. The control pintle may be rotated 446 mm (17.5 in.) on each side of center position to permit full reversal of output shaft. Pintle travel is limited to 35° by internal stops. Torque required to rotate control pintle is approximately 6.7 Nm (60 in. lbs.) at rated speed and pressure.

Shaft Rotation	Lever Position	Inlet Port
R.H.	1	B
R.H.	2	A
L.H.	1	A
L.H.	2	B

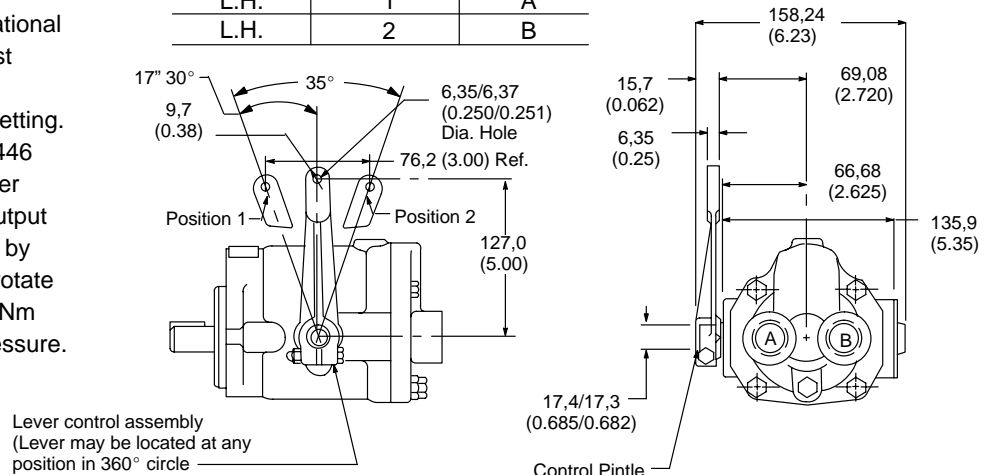

MVB10 Model Series

Performance Characteristics

Based on oil temperature of 49° C (120° F), 20.6 cSt (100 SUS)

Input Flow

USgpm L/min

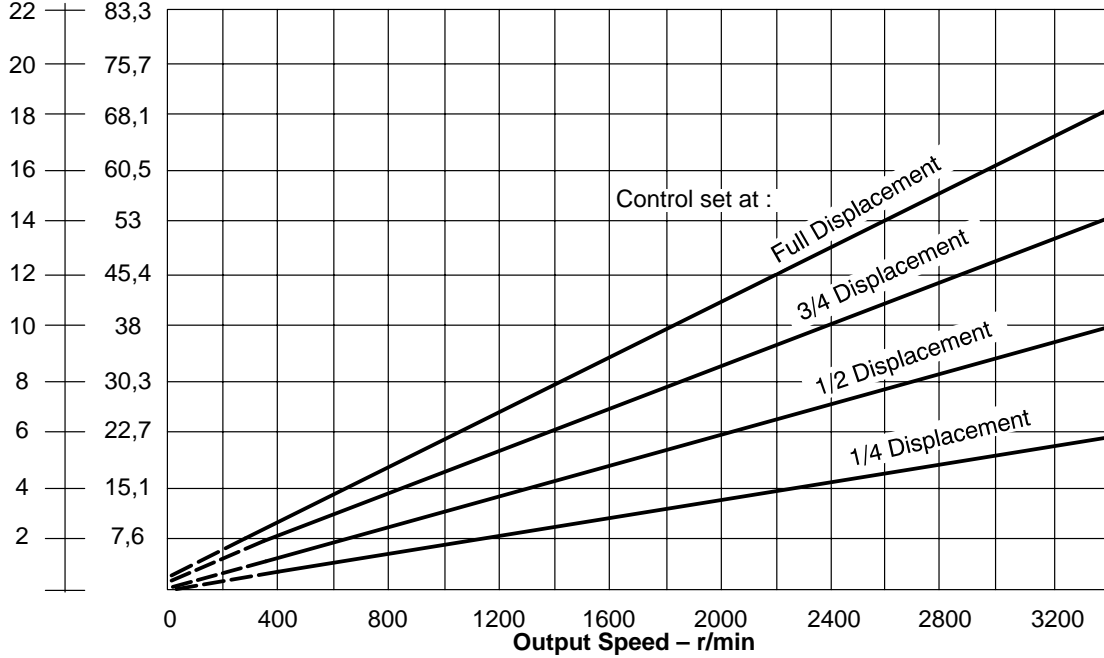

Input Pressure

bar psi

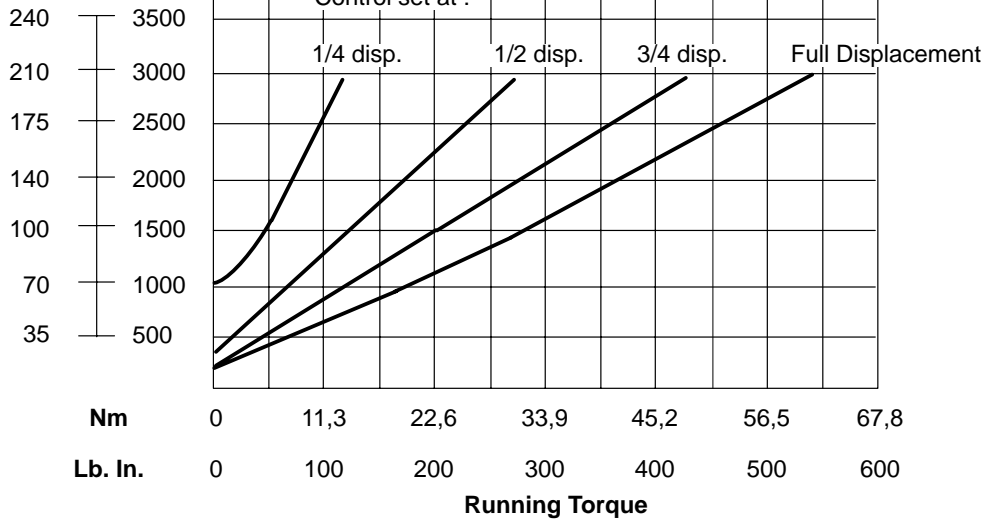

MVB10 Model Series with Handwheel or Lever Control

Installation Dimensions

Millimeters (inches)

Handwheel Control

Provides manual selection of motor displacement. Handwheel controlled units may be operated on either side of center permitting bi-directional output rotation.

Shaft Rotation	Pointer Position	Handwheel Rotation from Zero	Inlet Port
R.H.	1	Clockwise	B
R.H.	2	Counter-clockwise	A
L.H.	1	Clockwise	A
L.H.	2	Counter-clockwise	B

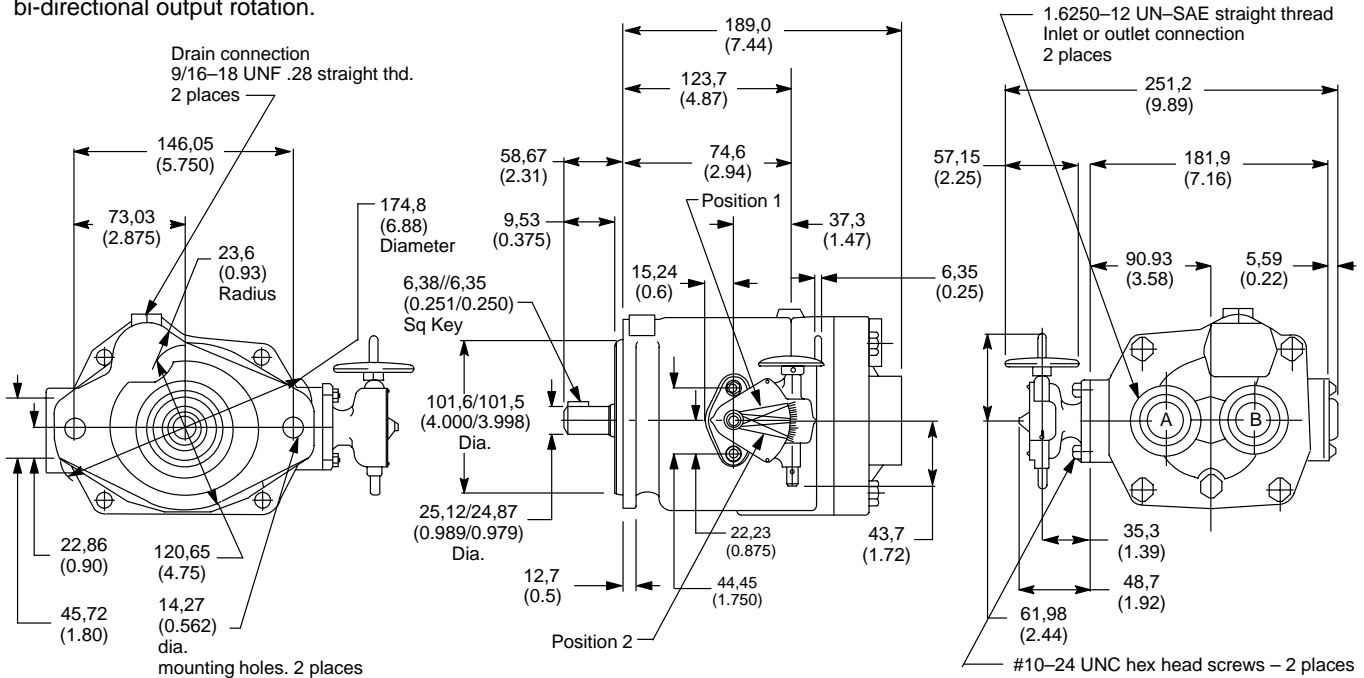

Lever Control

Provides mechanical or manual selection of motor displacement. Lever controlled units may be operated on either side of center permitting bi-directional output rotational characteristics. Lever controls must be secured by a suitable linkage arrangement to maintain desired setting. The control pintle may be rotated 446mm (17.5 in.) on each side of center position to permit full reversal of output shaft. Pintle travel is limited to 35° by internal stops. Torque required to rotate control pintle is approximately 6.7 Nm (60 in. lbs.) at rated speed and pressure.

Shaft Rotation	Lever Position	Inlet Port
R.H.	1	B
R.H.	2	A
L.H.	1	A
L.H.	2	B

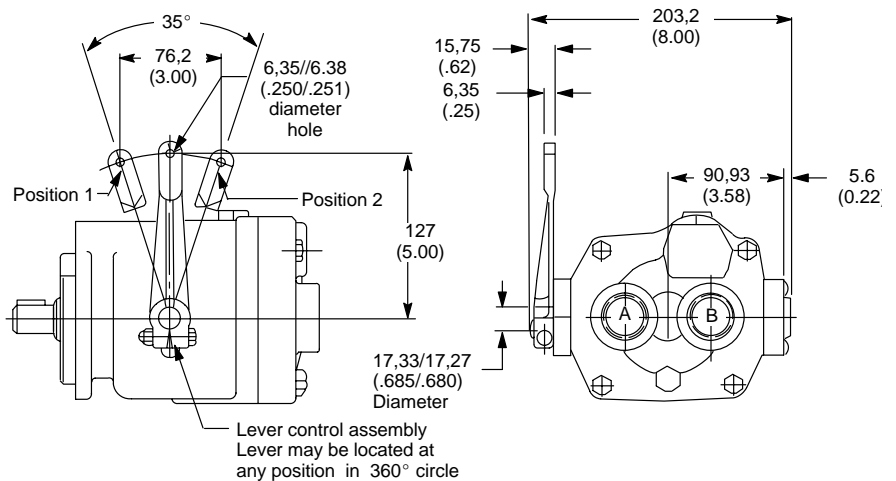

MVE19 Model Series

Circuit Diagram

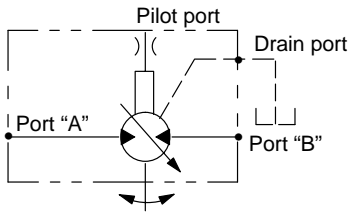

Ratings

Model & Theoretical Maximum Displacement cm ³ /rev (in ³ /rev)	Maximum Rated Input Speed	Maximum Rated Output Speed	Maximum Intermittent Pressure	Maximum Continuous Pressure	Rated Power
MVE19 40,9 (2.5)	3600 r/min	3600 r/min	350 bar (5000 psi) 210 bar (3000 psi) for "P" control	210 bar (3000 psi)	16,8 kW per 1000 r/min (22.5 hp per 1000 r/min)

Model Code

M V E 19 X - 2 - 30 - A - 7 - 10 - 030

1 Model Series

MVE – Variable displacement piston motor

2 Rated Flow

19 – 72 L/min (19 USgpm)

3 Thru Shaft

Blank – No thru shaft
X – Available only on side ported models. Use for static brake only.

4 Output Shaft

2 – SAE B–B splined
9 – SAE B splined*

* #9 shaft is limited to max pressure of 210 bar (3000 psi)

5 Motor Design Number

Subject to change. Installation dimensions remain as shown for designs 30 through 39.

6 Control & Location

A – Right hand pintle location viewed from shaft end with drain port up

B – Left hand pintle location viewed from shaft end with drain port up

M – External pilot control ("Vented" equals minimum stroke/maximum speed) †

P – External pilot control. See above pressure restrictions under "Ratings". ("Vented" equals maximum stroke/minimum speed) †

† External pilot pressure must be equal to the system pressure to ensure yoke position.

7 Minimum Displacement Angle

Any angle from 7° to 15° in 2° increments

8 Control Design Number

10 – Subject to change

9 Special Suffix

Blank – No special features
030 – End ports

MVE19 Model Series with Control Pintle & Side Ports

Installation Dimensions Millimeters (inches)

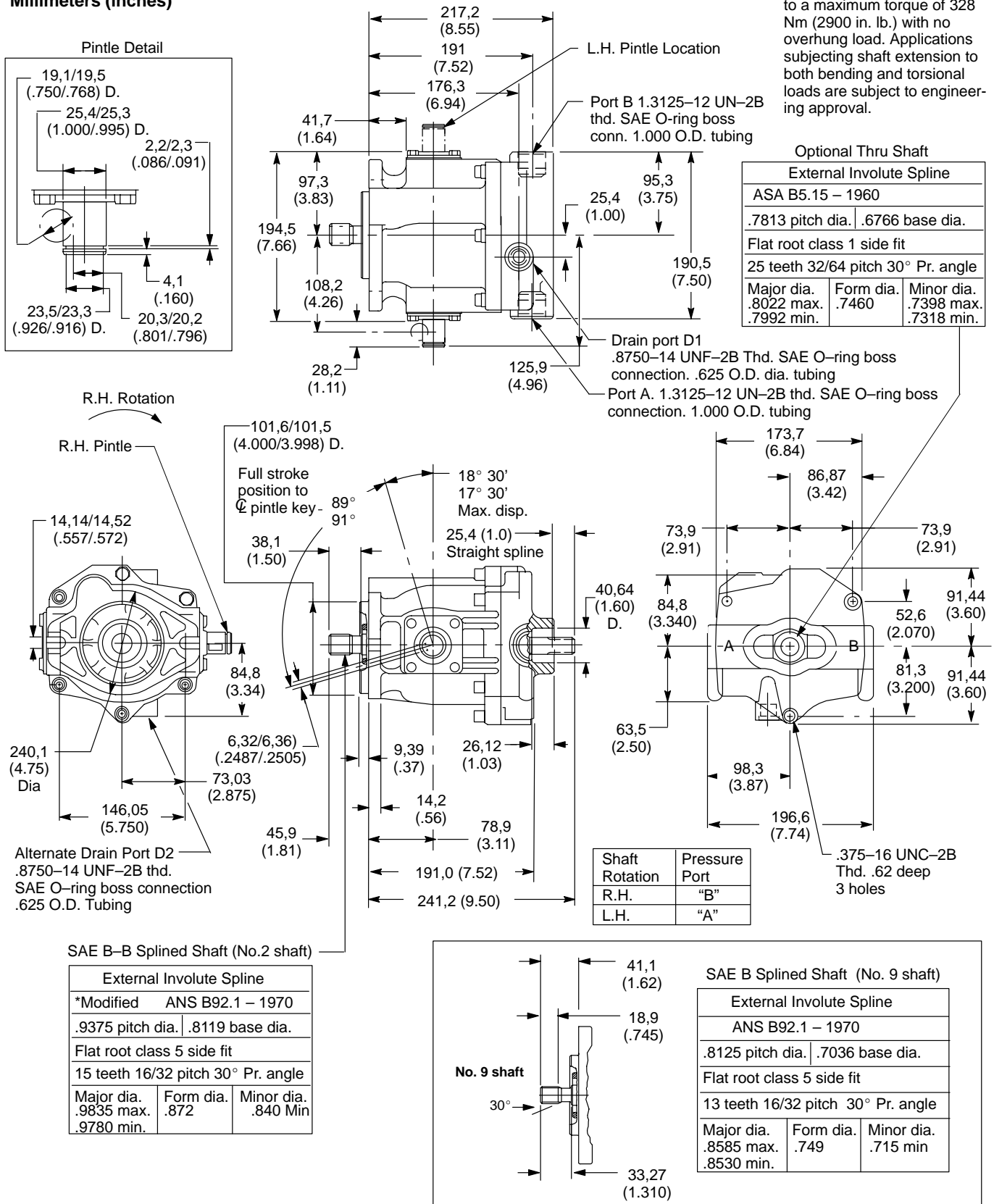

MVE19 Model Series with Pilot Control & Side Ports

Installation Dimensions Millimeters (inches)

Shaft Rotation	Pressure Port
R.H.	"B"
L.H.	"A"

Thru shaft extension is limited to a maximum torque of 328 Nm (2900 in. lb.) with no overhung load. Applications subjecting shaft extension to both bending and torsional loads are subject to engineering approval.

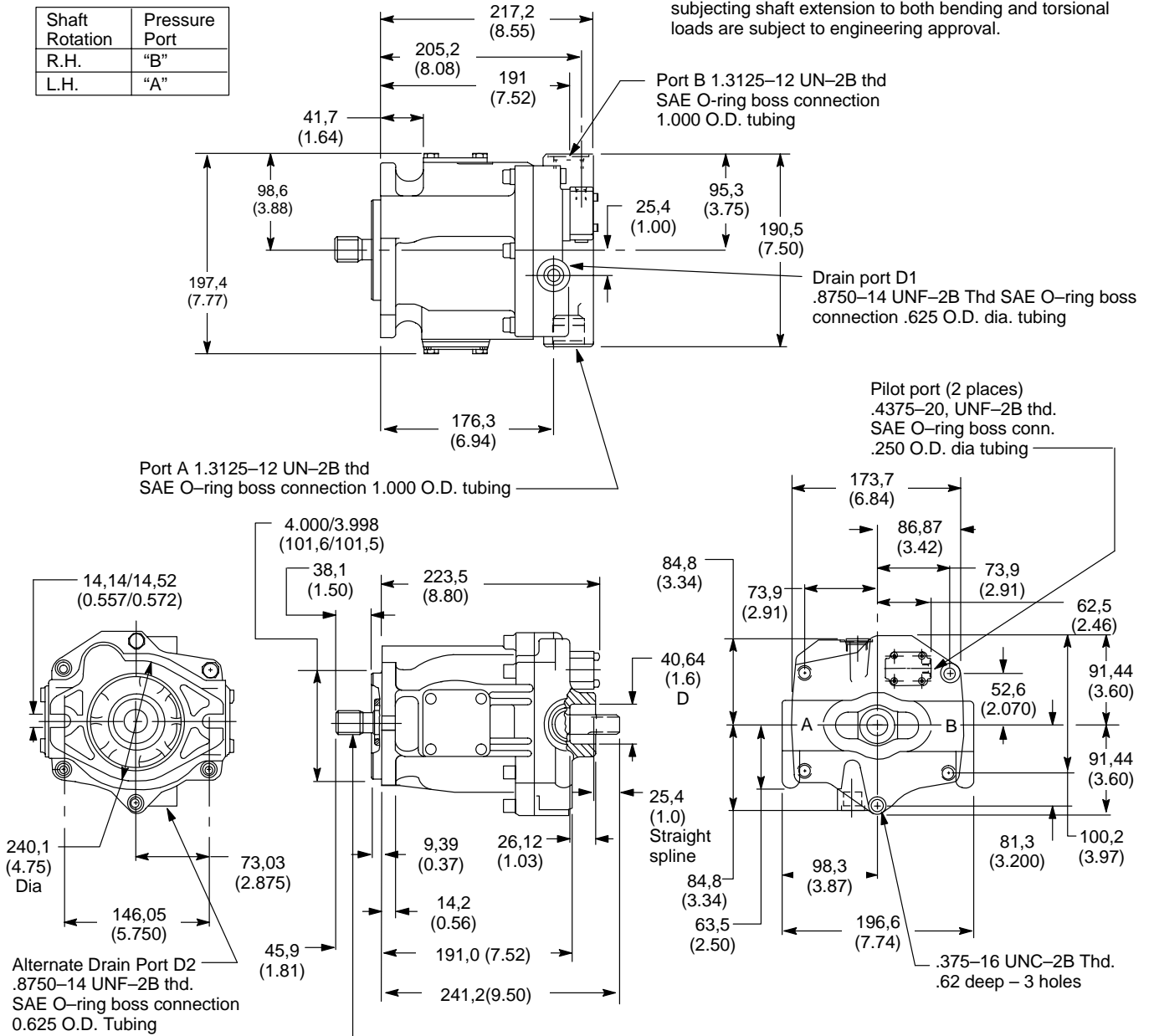

SAE B-B Splined Shaft (No.2 shaft)

External Involute Spline		
*Modified ANS B92.1 - 1970		
.9375 pitch dia. .8119 base dia.		
Flat root class 5 side fit		
15 teeth 16/32 pitch 30° Pr. angle		
Major dia.	Form dia.	Minor dia.
.9835 max.	.872	.840 min
.9780 min.		

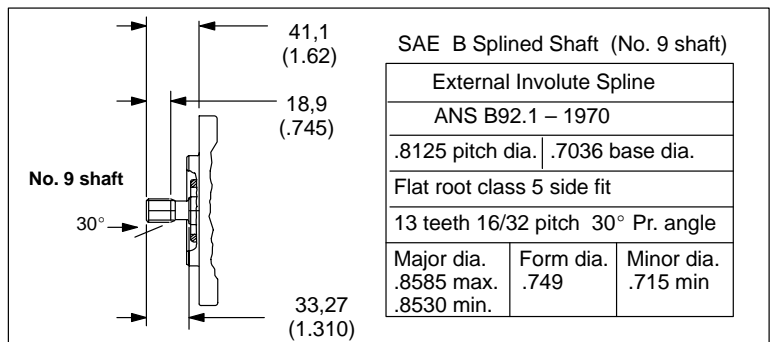

SAE B Splined Shaft (No. 9 shaft)

External Involute Spline		
ANS B92.1 - 1970		
.8125 pitch dia. .7036 base dia.		
Flat root class 5 side fit		
13 teeth 16/32 pitch 30° Pr. angle		
Major dia.	Form dia.	Minor dia.
.8585 max.	.749	.715 min
.8530 min.		

MVE19 Model Series with Control Pintle & End Ports

Installation Dimensions

Millimeters (inches)

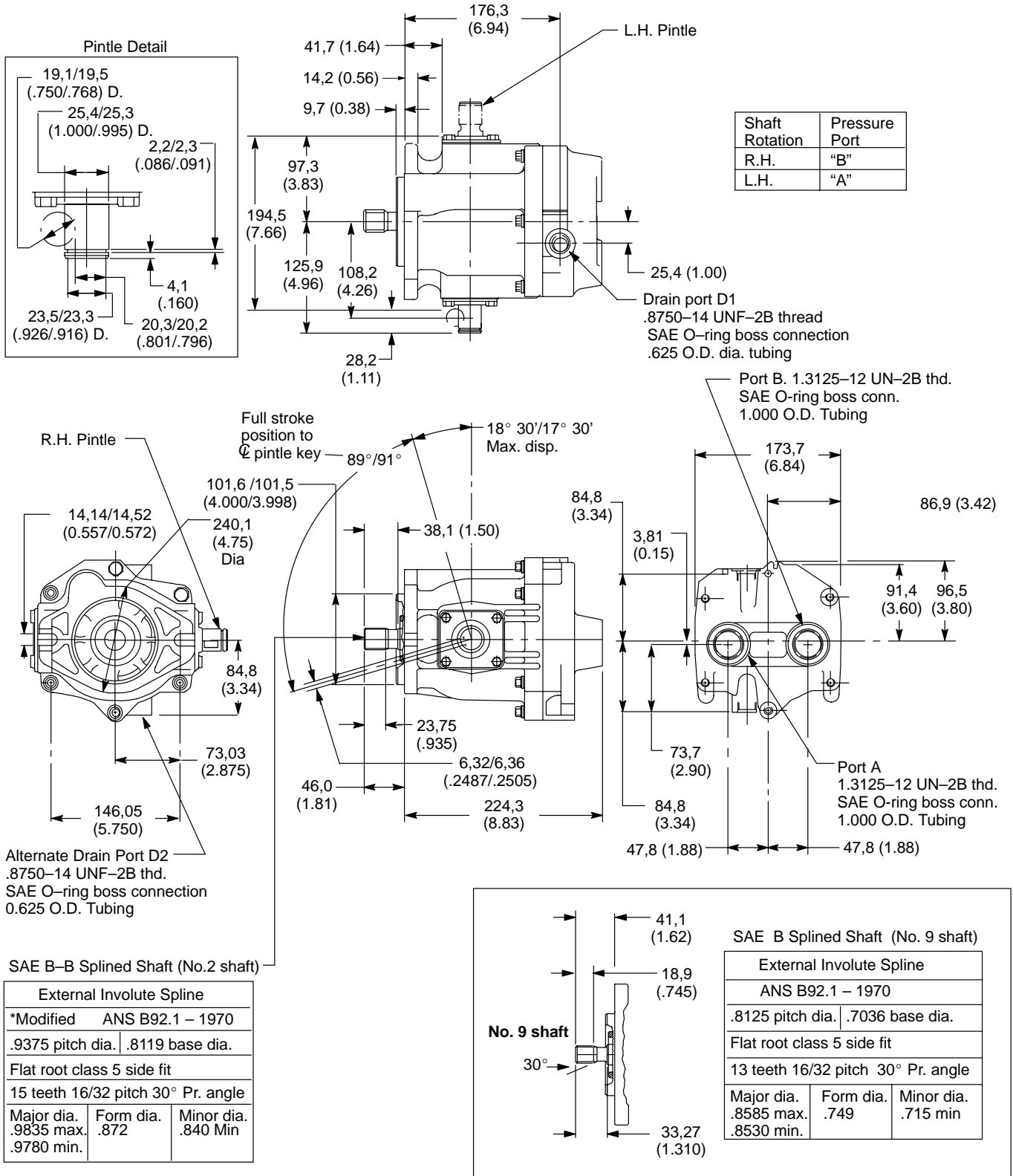

MVE19 Model Series with Pilot Control & End Ports

Installation Dimensions

Millimeters (inches)

Shaft Rotation	Pressure Port
R.H.	"B"
L.H.	"A"

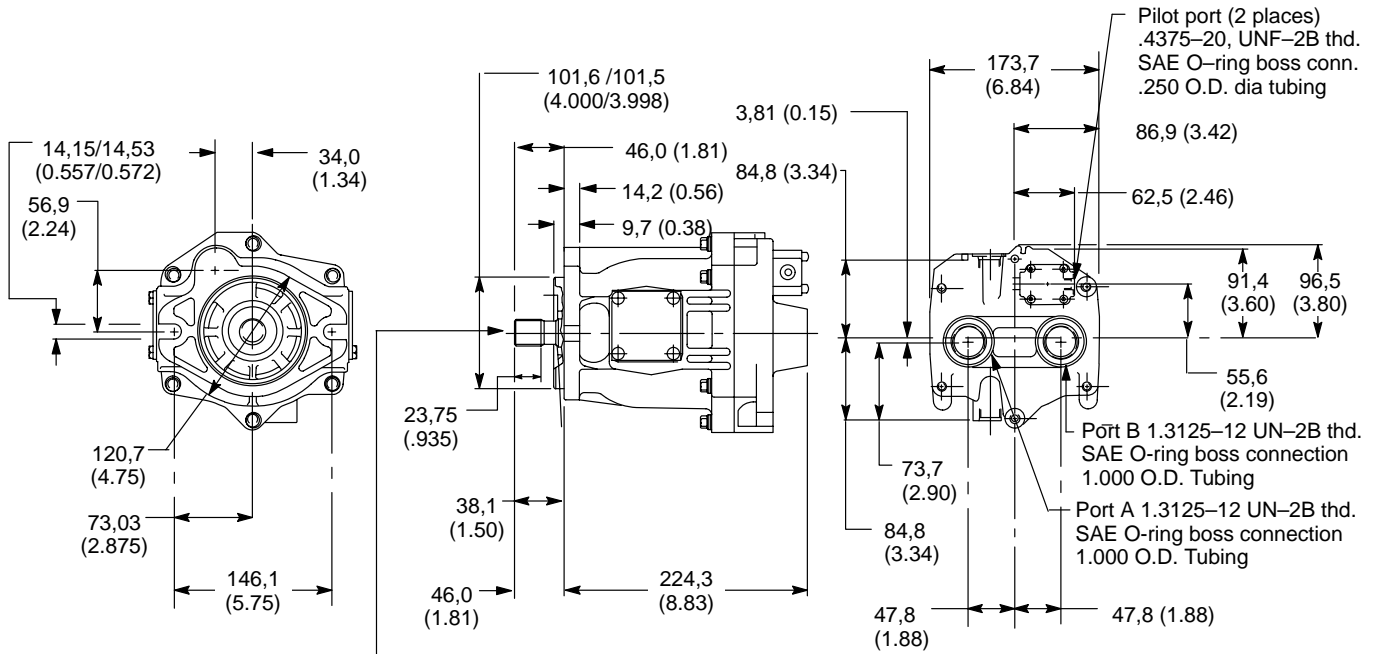
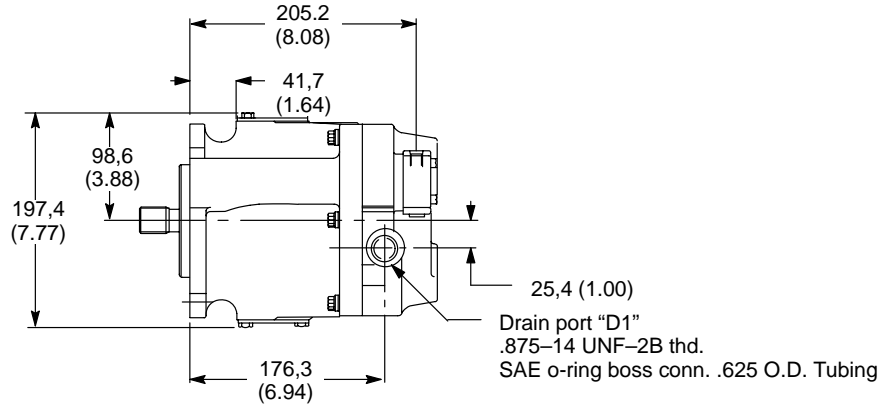

SAE B-B Splined Shaft (No.2 shaft)

External Involute Spline		
*Modified ANS B92.1 - 1970		
.9375 pitch dia. .8119 base dia.		
Flat root class 5 side fit		
15 teeth 16/32 pitch 30° Pr. angle		
Major dia. .9835 max. .9780 min.	Form dia. .872	Minor dia. .840 Min

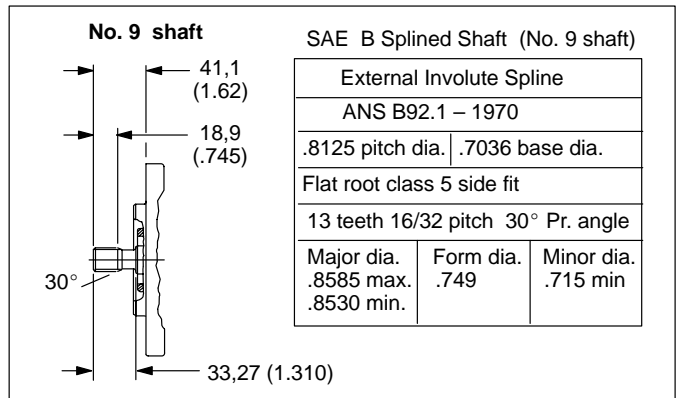

Foot Mounting Bracket

The foot bracket kits tabulated below can be used to mount motors having standard SAE-J 744 2-bolt A, B, or C mounting flanges. These designations correspond to -A-, -B-, and -C- letters in the foot bracket kit model number. Each kit includes a bracket and screws for mounting to the motor. Kits are not included with motors and must be ordered separately by model number.

Also available are a bracket (part number 279625) and mounting screws (part number 214794, 2 required) to fit the SAE D mounting flange.

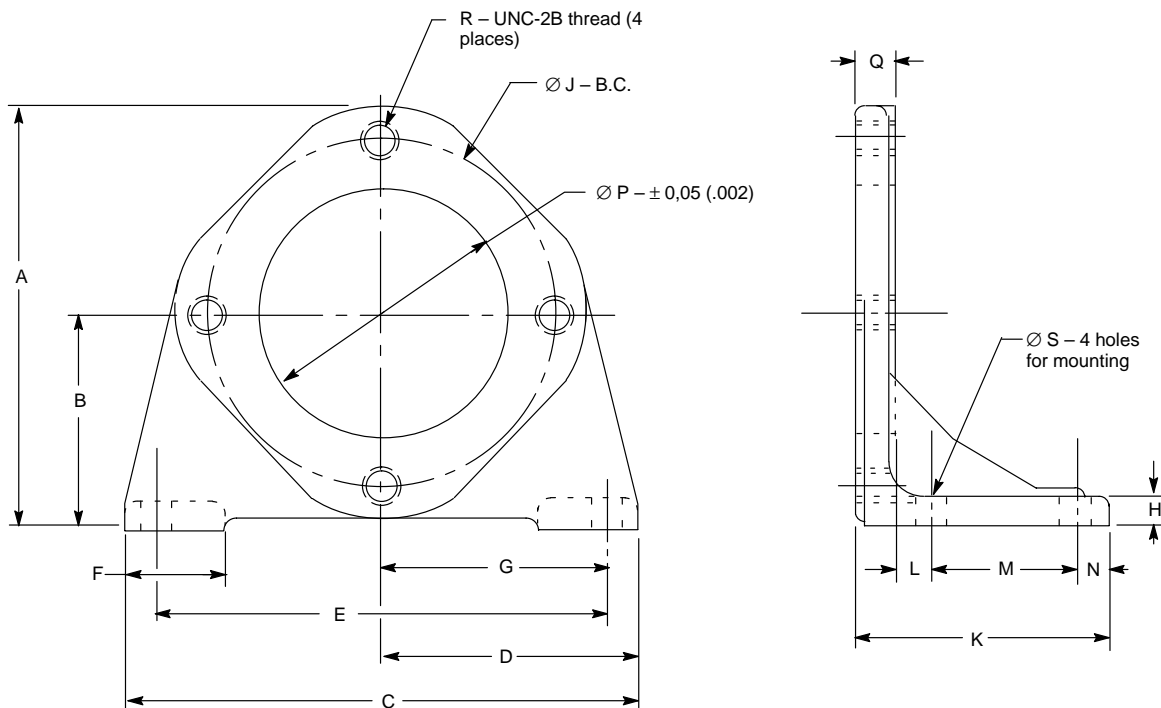

Kit model number	Dimensions millimeter (inch)							
	A	B	C	D	E	F	G	H
FB-A-10	134,9 (5.31)	69,9 (2.75)	152,4 (6.00)	76,2 (3.00)	127 (5.00)	36,6 (1.44)	63,5 (2.50)	12,7 (.50)
FB-B-10	180,8 (7.12)	92,2 (3.63)	171,5 (6.75)	85,8 (3.38)	146 (5.75)	36,6 (1.44)	73,2 (2.88)	12,7 (.50)
FB-C-10	215,9 (8.50)	109,5 (4.31)	265,2 (10.44)	132,6 (5.22)	235 (9.25)	50,8 (2.00)	117,6 (4.63)	15,7 (.62)

Kit model number	Dimensions millimeter (inch)								
	Ø J	K	L	M	N	Ø P	Q	R	Ø S
FB-A-10	106,4 (4.19)	96 (3.78)	15 (.59)	50,8 (2.00)	12,7 (.50)	82,63 (3.253)	17,5 (.69)	.38-16	11,2 (.44)
FB-B-10	146 (5.75)	95,8 (3.77)	15 (.59)	50,8 (2.00)	12,7 (.50)	101,68(4.003)	17,3 (.68)	.50-13	17,3 (.68)
FB-C-10	181,1 (7.13)	131,6 (5.18)	19 (.75)	76,2 (3.00)	17,3 (.68)	127,08(5.003)	19 (.75)	.62-11	17,3 (.68)

Application and Service Information

Hydraulic fluids

Vickers motors can be used with anti-wear hydraulic oil, or automotive type crankcase oil (designations SC, SD, SE, SF, or SG) per SAE J183 JUN89. Fire-resistant fluids can also be used, but may require the use of special seals as explained in the following “Seals” section.

The fluid viscosity range with the pump running should be 13-54 cSt (70-250 SUS). An operating temperature of 49°C (120°F) is recommended. For additional fluid and temperature information, refer to 694.

Seals

Nitrile seals are standard in Vickers inline motors. These seals are suitable for use with petroleum, water-glycol, water-in-oil emulsion, polyol ester, and high-water-base fluids. Phosphate ester fluids require the use of fluorocarbon seals, which are identified in applicable model codes by an “F3” prefix.

Installation and Startup

Horizontal mounting is recommended to maintain the necessary case fluid level.

Before starting, fill the case with system fluid through the uppermost drain port. The housing must be kept full at all times to provide internal lubrication.

The case drain line must be full size, unrestricted, and connected from the uppermost drain port directly to the reservoir in such a manner that the housing remains filled with fluid. The line must be piped to prevent siphoning and must terminate below the reservoir fluid level. No other lines are to be connected to this drain line.

At initial startup, it may be necessary to bleed air from the pump outlet to permit priming and reduce noise. Bleed by loosening an outlet connection until a solid stream of fluid appears. An air bleed valve for this purpose is available through your Vickers representative.

Fluid cleanliness

Proper fluid condition is essential for long and satisfactory life of hydraulic components and systems. Hydraulic fluid must have the correct balance of cleanliness, materials and additives for protection against wear of components, elevated viscosity and inclusion of air.

Essential information on the correct methods for treating hydraulic fluid is included in Vickers publication 561; “Vickers Guide to Systemic Contamination Control,” available from your local Vickers distributor or by contacting Vickers, Incorporated. Recommendations on filtration and the selection of products to control fluid condition are included in 561.

Recommended cleanliness levels, using petroleum oil under common conditions, are based on the highest fluid pressure levels in the system and are coded in the chart below. Fluids other than petroleum, severe service cycles, or personnel safety considerations are cause for adjustment of these cleanliness codes. See Vickers publication 561 for exact details.

Vickers products, as any components, will operate with apparent satisfaction in fluids with higher cleanliness codes than those described. Other manufacturers will often recommend levels above those specified. Experience has shown, however, that life of any hydraulic components is shortened in fluids with higher cleanliness codes than those listed below. These codes have been proven to provide a long trouble-free service life for the products shown, regardless of the manufacturer.

Cleanliness codes for petroleum oil usage

Product	System Pressure Level		
	< 140 bar (< 2000 psi)	140-210 bar (2000-3000 psi)	210+bar (3000+ psi)
Swash plate design motors	18/16/14	17/15/13	16/14/12