

EAT•N

Hydraulics

Medium Duty Hydrostatic Drives

Principle of Operation

70360 Piston Pump

74318 Piston Motor



Medium Duty Hydrostatic Drive Principle of Operation

There are many methods used to transmit engine power to the driven wheels of a vehicle. These methods range from the standard manual gear shift, to the more sophisticated hydrostatic propulsion drive.

The main advantage of the propulsion drive is the infinite speed ratios that can be obtained by being able to control the piston pump cam angle, from the neutral position, to full cam forward or reverse position. The direction and speed of the vehicle can be changed without changing the input shaft rotation of the pump.

The simplest type of hydrostatic propulsion drive consists of a variable piston pump with a gerotor charge pump and a fixed displacement piston motor. When the drive shaft of the piston pump is rotated by an external force, the piston block which is splined to the drive shaft also turns. The piston block contains nine piston assemblies which have a free swiveling shoe on the ball end of the piston assembly. The shoe end of the piston rides against the smooth surface of the camplate. With the camplate in the neutral position (figure 1) the piston assemblies do not reciprocate in the piston block, they just merely rotate, no oil is being drawn in or discharged from the pump. The pump is in a zero displacement position and the vehicle remains stationary.

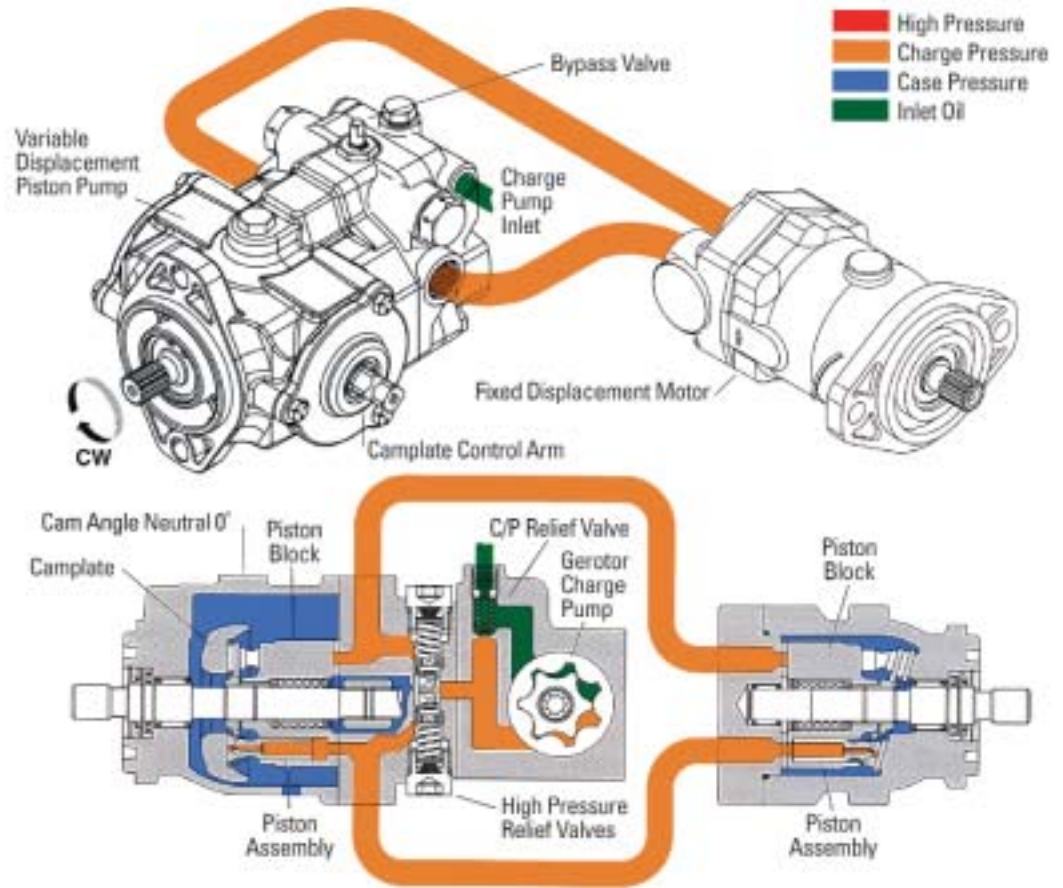

Figure 1 – CAM Angle Neutral Position

The purpose of the gerotor charge pump is to keep the closed loop full by replenishing the oil that is lost through internal leakage at the piston pump and motor. The gerotor charge pump also keeps the intake or low pressure side of the system primed with oil.

The two high pressure relief valves are dual purpose valves. The primary function is to provide overload protection to the system, the secondary function serves as a charge check valve.

With the camplate in the 0° or neutral position the pressure of the charge oil, which ranges from 4 to 20 Bar [60 to 300 PSI], depending on charge relief setting, is able to unseat both relief valves, which also serve as charge checks. This allows fluid to be supplied to both sides of the loop at charge relief pressure setting. There is very little internal leakage while the camplate is in the 0° position so excess charge oil is bypassed over the charge pump relief valve and recirculated back into the

intake side of the gerotor charge pump, or relieved to case. The oil that leaks internally in the pump and motor collects in their body housings and is returned to the reservoir via a case drain in each the pump and motor housing. This is the only oil returning to the reservoir in a closed loop system, unless the charge flow is relieved to case.

As the control lever is slowly moved forward the vehicle starts a forward movement (figure 2). As the camplate begins to move, the piston assemblies start to reciprocate in the piston block. As the control lever continues a forward movement the cam angle increases, the pistons reciprocate further, more oil is being pumped and the speed of the vehicle is increased. The control lever can be moved forward until a full cam angle of 17° has been reached, which also achieves maximum volume of oil being discharged from the pump. When the camplate begins to move, the relief valve, on the discharge or pressure side seats because of the higher pressure differential. The other relief valve, which serves as a charge check remains open on the intake or low pressure side to continue supplying the closed loop system with a charge of oil.

The motor, which is this case is a fixed displacement type, delivers a constant output torque for a given pressure throughout the speed range of the motor. The speed of the motor is dictated by the volume of oil discharged from the pump. A low camplate angle delivers a small volume of oil, causing the motor to turn slowly. As the camplate angle increases, the speed of the motor increases until the maximum camplate angle of the pump is reached.

The movement of the pump camplate from 0° to 17° in either the forward or reverse position controls the direction of rotation of the motor.

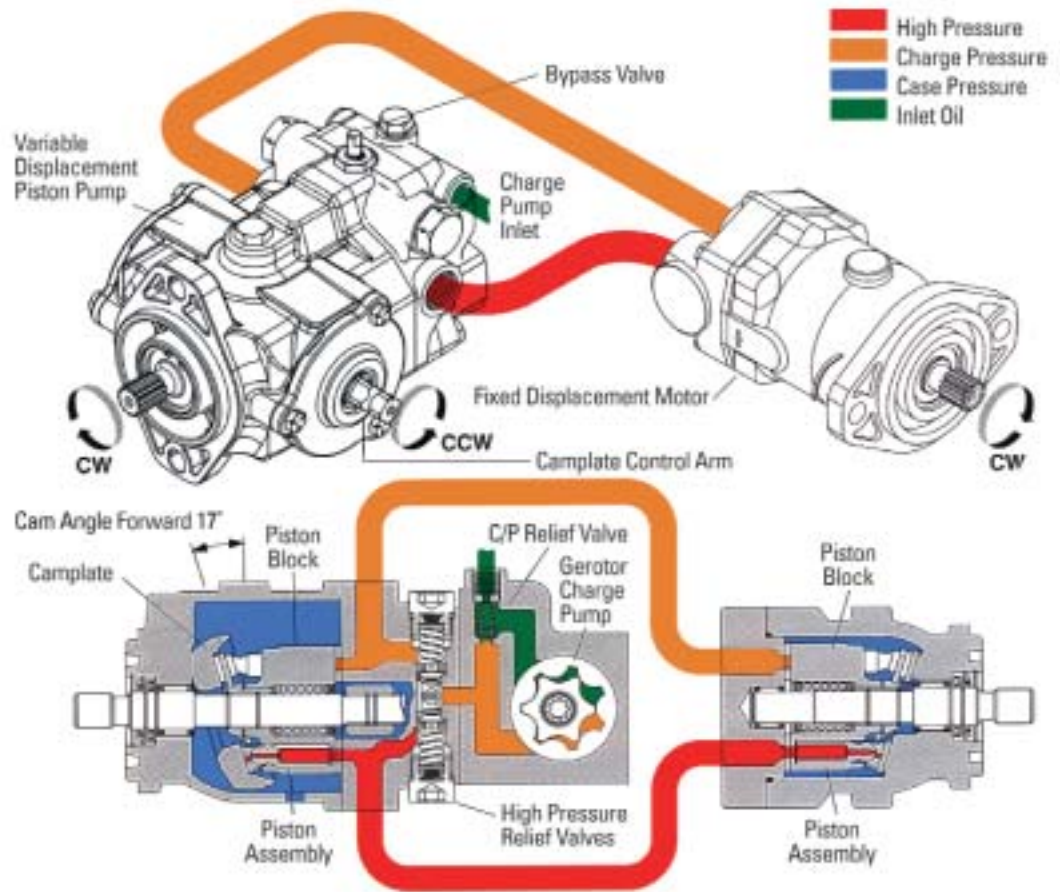

Figure 2 – Cam Angle Forward Position

Medium Duty Hydrostatic Drive Principle of Operation

Figure 3 shows the camplate in the full 17° forward position with the relief valve cross relieving. The function of the system relief valve is to relieve the pressure side of the system of excessive high pressure when the vehicle encounters a heavy load or stalls out.

The high pressure surrounding the direct acting relief valve enters the relief valve body in the relief valve cartridge. This pressurized oil causes the relief valve to open. A volume of oil flows across to the other relief valve. This relief valve is exposed to low pressure on the intake side of the pump and is seated by the charge check spring tension within the relief valve body. The pressure of the volume of oil being bypassed is enough to unseat the charge check function of the relief valve and let it recirculate back into the intake side of the pump.

Caution must be taken when oil is bypassed over the relief valves because the high pressure and volume of oil being bypassed, quickly builds up heat which can damage the pump.

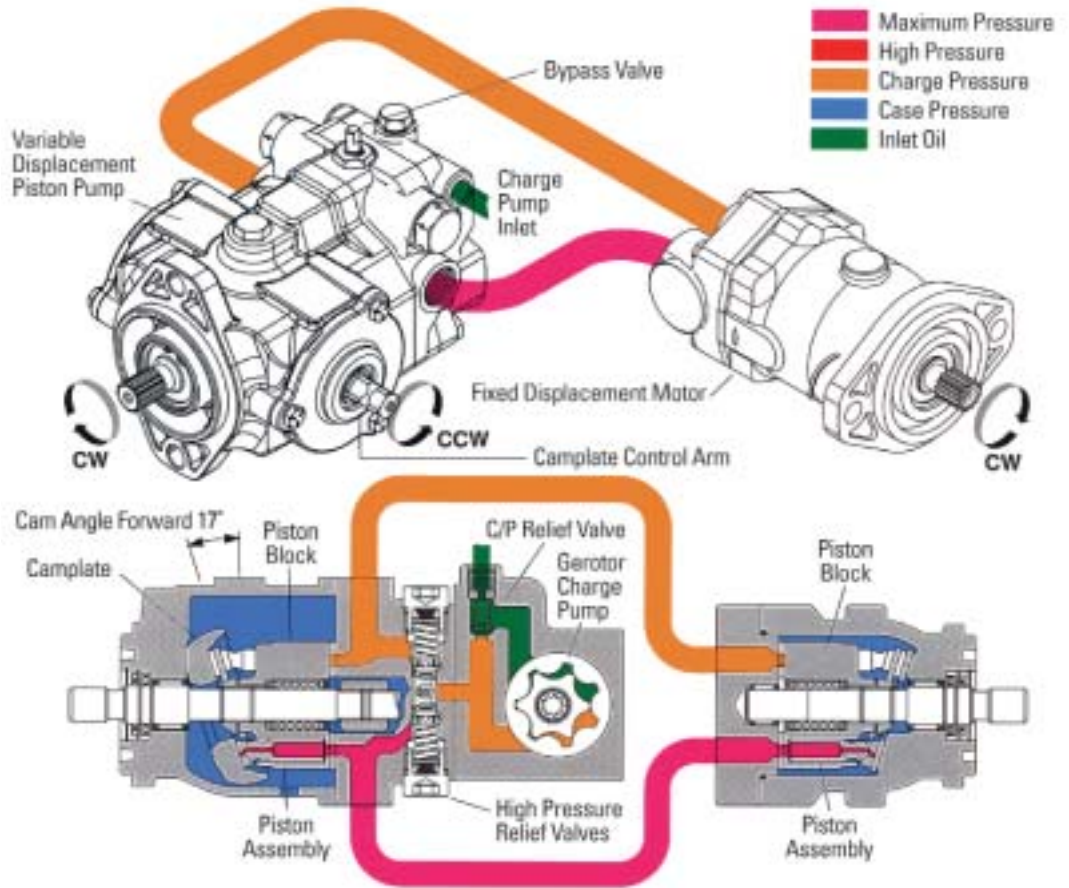

Figure 3 – Cam Angle Forward Position with Relief Valve Cross Relieving

When the control lever is slowly moved to the reverse position, the vehicle starts a reverse movement (figure 4).

The control lever can be moved in reverse until a full cam angle of 17° has been reached, which also achieves maximum volume of oil being discharged from the pump. When the camplate begins to move, the relief valve, which serves as a charge check, remains open on the intake or low pressure side to continue supplying the closed loop system with a charge of oil.

In the reverse position the pump shaft still rotates in the same direction, but the discharge of oil, from the pump is reversed, thus reversing the rotation of the motor.

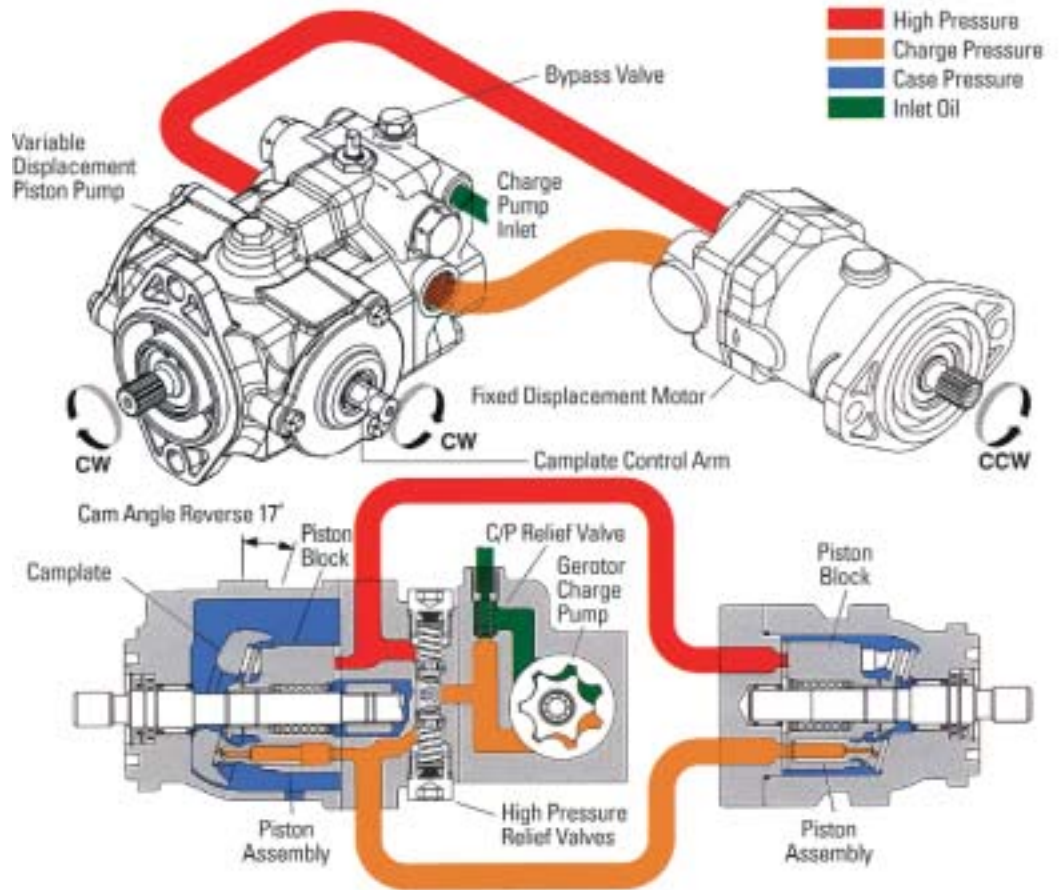

Figure 4 – Cam Angle Reverse Position

Propulsion Pump High Pressure Relief Valve

The purpose of the high pressure relief valve in the propulsion pump is to relieve the pressure side of the pump of excessive high pressure when the vehicle encounters a heavy load or stalls out.

Figure 5 shows the position of the poppet when the system is operating under normal working pressure. This normal working pressure is unable to overcome the high pressure spring so the relief valve seat remains seated.

Figure 6 shows the relief valves "cross-relieving." When the vehicle stalls out or encounters a heavy load, the pressure increases. This high pressure causes the direct acting relief valve to open. The oil pressure forces the poppet to move and compress the high pressure spring until the relief valve pressure setting is obtained. This flow of oil unseats the cartridge of the opposite relief valve which is held by the charge check spring. This volume of oil that is flowing across, passes through the cartridge, and is allowed to recirculate back into the intake side of the pump. Maximum volume of oil is relieved until the load is overcome or the operator returns the pump camplate to the neutral position. The relief valve cartridges, and poppets then return back to the position shown in figure 5. The high pressure relief valve functions the same for both sides of the system.

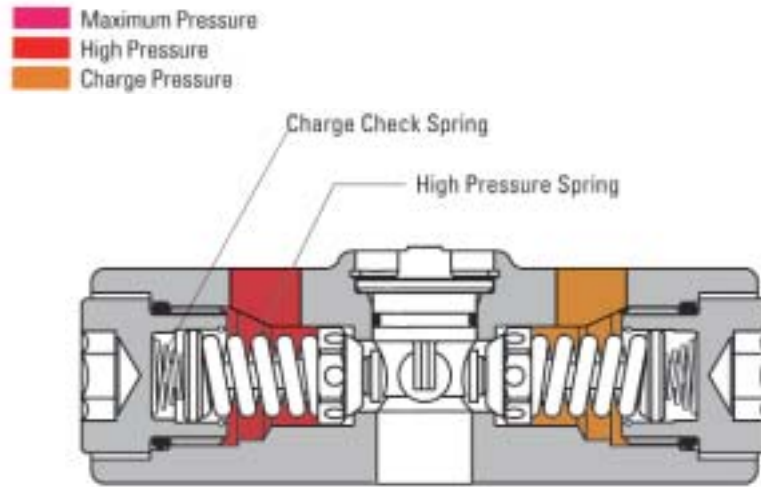

Figure 5 – High Pressure Relief Valve - Normal Operations

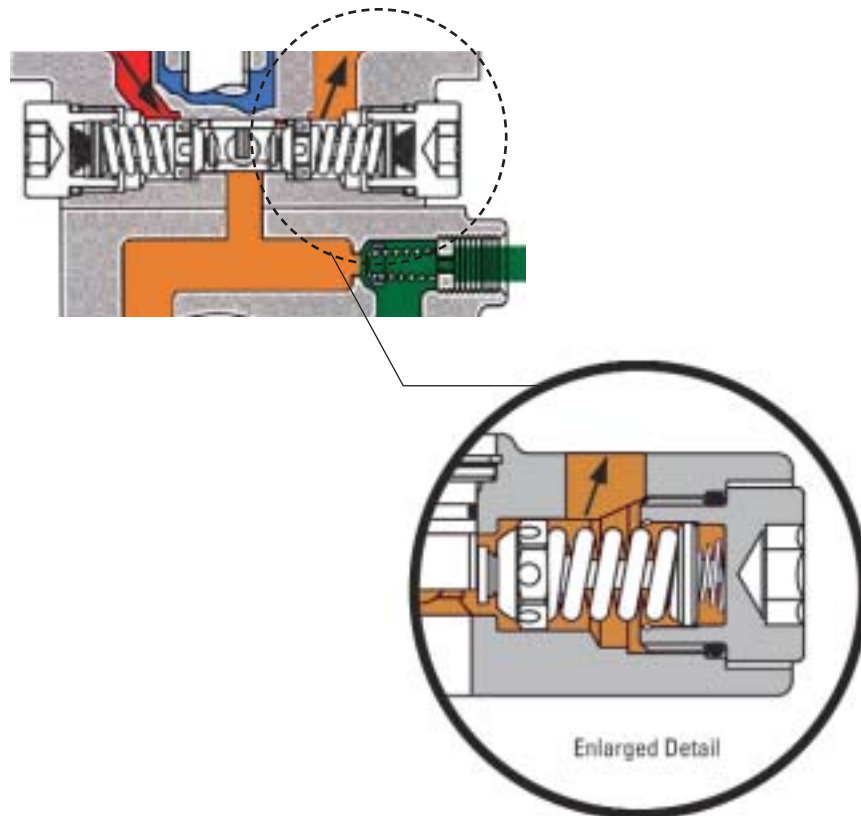

Figure 6 – High Pressure Reliefs – "Cross Relieving"

Operation of Bypass Valve

The purpose of the bypass valve is to allow the movement of a disabled machine or if you have a machine that you just want to push a short distance without starting the engine. When a hydrostatic driven machine is shut down, it is virtually impossible to move the machine without disengaging the hydrostatic closed loop circuit. If an attempt is made to push the machine, the hydraulic motor becomes a pump, trying to pump oil to the hydrostatic pump. This creates a hydraulic lock between the motor and the pump. To overcome this condition, a bypass valve has been installed between the high pressure relief valves in the back plate of the piston pump. The bypass valve is a plug that contains a rotating stem which has a flat spade end that fits between the two ends of the high pressure relief valves. When the bypass valve is not required in the "closed" position, the relief valves are in the normal operating position as shown in the top illustration. When the bypass valve stem is rotated 90 degrees, the flat spade end spreads the relief valves to the "open" position as

shown in the lower illustration. This allows the oil in the hydrostatic closed loop to "bypass" around the high-pressure relief valves inside the pump backplate. The by-pass-

ing of oil inside to pump backplate will allow the motor to rotate freely when the vehicle is moved a short distance. The bypass valve is intended for moving a machine only a

very short distance and is not intended for towing a vehicle behind a truck or tractor. Serious damage to the hydrostatic drive will result if the vehicle is towed.

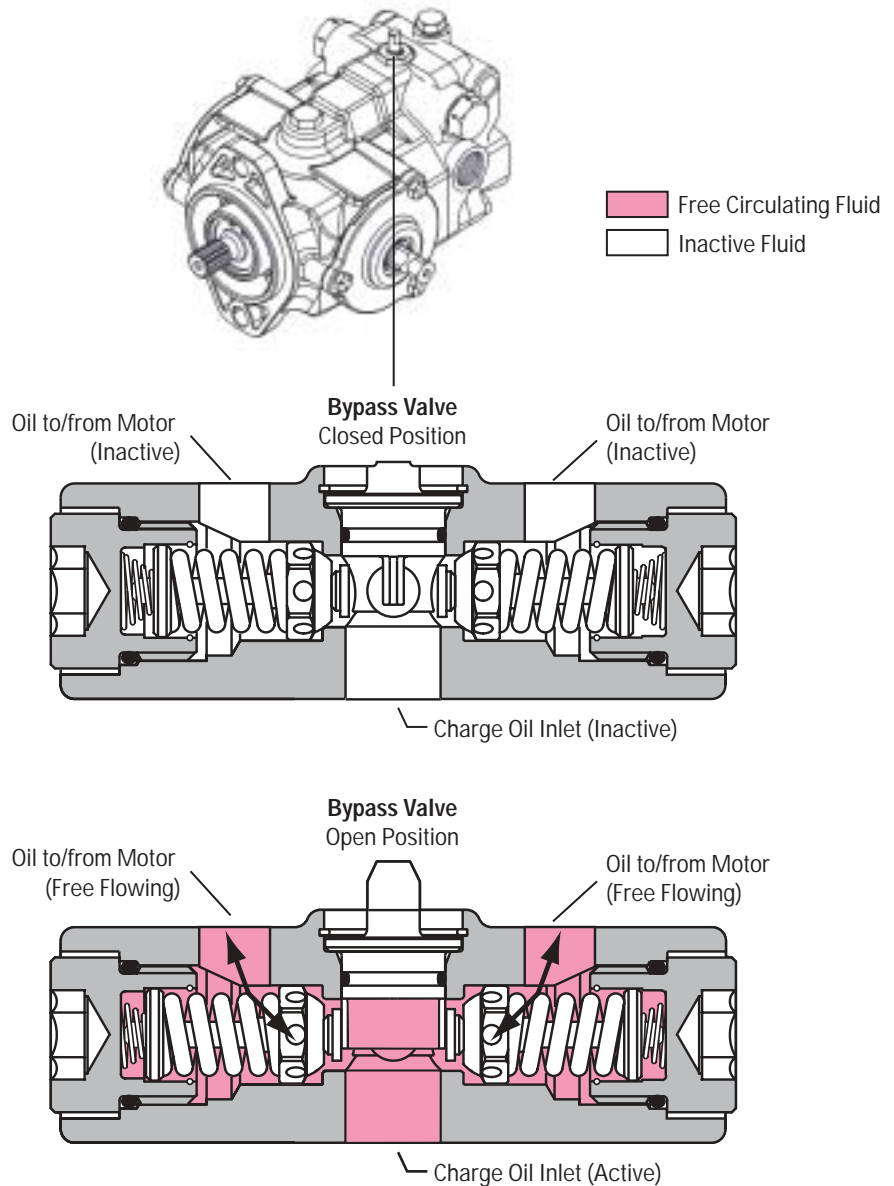

Figure 7 – Bypass Valve Operation

Eaton
14615 Lone Oak Road
Eden Prairie, MN 55344
USA
Tel: 952 937-9800
Fax: 952 974-7722
www.hydraulics.eaton.com

Eaton
20 Rosamond Road
Footscray
Victoria 3011
Australia
Tel: (61) 3 9319 8222
Fax: (61) 3 9318 5714

Eaton
Dr.-Reckeweg-Str. 1
D-76532 Baden-Baden
Germany
Tel: (49) 7221 682-0
Fax: (49) 7221 682-788



Hydraulics

© 2003 Eaton Corporation
All Rights Reserved
Printed in USA
Document No. E-PUPI-MC002-E
December 2003