

**EATON** | **Vickers**

## Hydrokraft Piston Motors

Technical Catalog

MVX

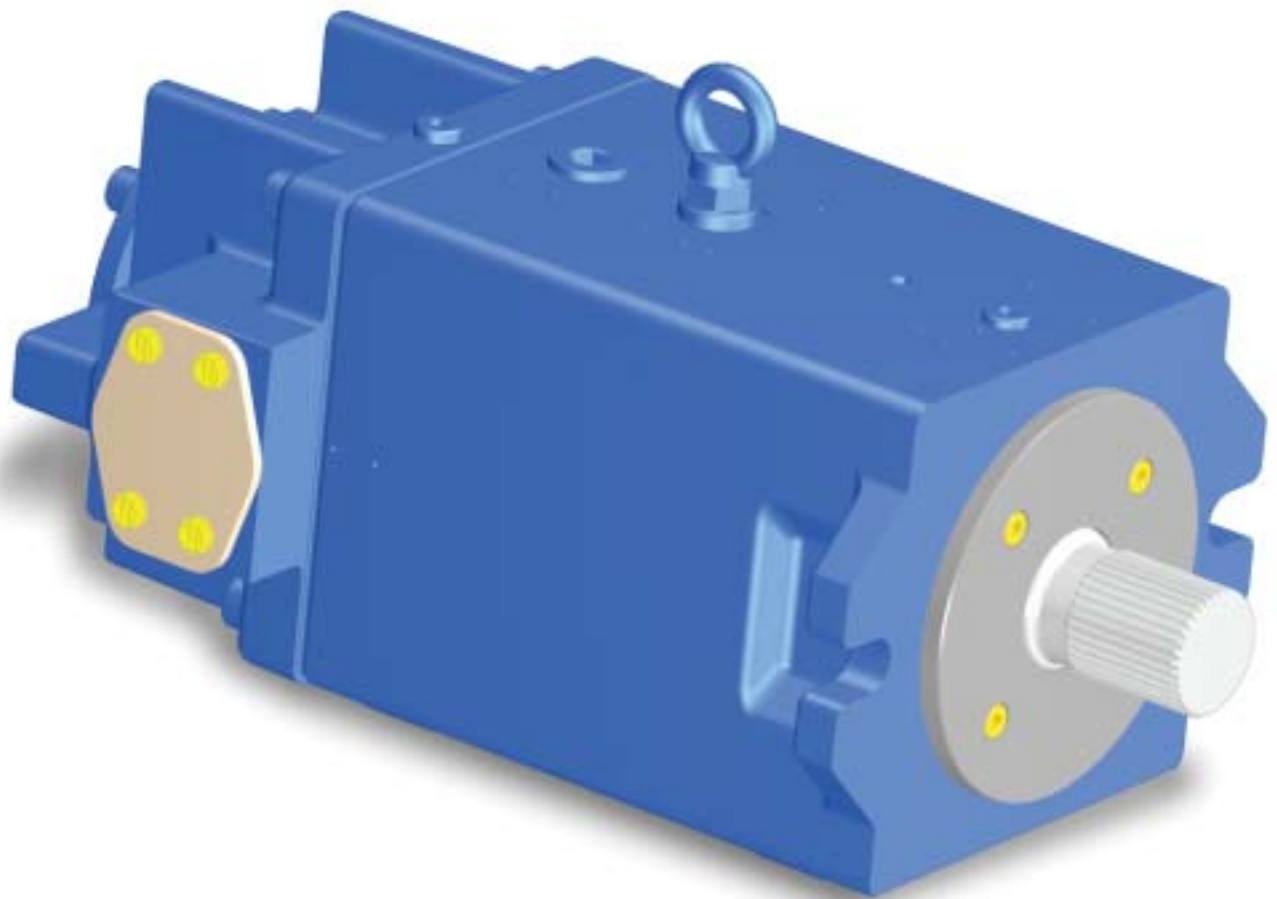

**VICKERS**<sup>®</sup>

# Table of Contents

Introduction .....	3
Model Code	
Form Page .....	4
Basic Motors .....	5
No Control .....	6
ES Control .....	7
HG Control .....	8
FE Control .....	9
DP Control .....	10
SP Control .....	11
Special Features .....	12
Motor Specifications	
US .....	13
Metric .....	14
Controls	
Electric Motor Displacement Control, ES .....	15
Manual Adjustment Displacement Control, FE, HG .....	16
Pressure Signal Adjustment Displacement Control, DP .....	17
Electrohydraulic Servo Adjustment, SP .....	18
Pump Dimensions*	
MFXS-066 - 180** .....	20
MVXS-066 - 180 ES Control** .....	22
MVXS-066 - 180 HG Control** .....	24
MVXS-066 - 180 FE Control** .....	26
MVXS-066 - 180 DP Control** .....	28
MVXS-066 - 180 SP Control** .....	30
Installation Data .....	32
Application Data	
Fluid Recommendations .....	33

\* Dimensions - MFXS -250 / MVXS-250 ask for special drawings.  
Used only for replacement.

For new applications please use MFWS / MVWS.

\*\* MFXS / MVXS -130/180, for new applications please use MFWS / MVWS-130/180.

# Introduction

- Axial piston motors with swashplate design and can be applied to hydrostatic drives.
- Pressure up to 350 bar. Rated speed up to 1800 min<sup>-1</sup>.
- A range of control options allow matching of motors to any application.
- Rotating and pressure loaded parts are pressure balanced.
- High efficiency from automatic pressure balancing of cylinder block to valve plate.
- Oversized shaft bearings for long life and thru-drive capability.
- Highly resistant to dirt because of automatic wear compensation.
- Low sound level assured by swashplate design and other proven features.

## AVAILABLE DISPLACEMENT SIZES

066 ccm
090 ccm
130 ccm
180 ccm

### Displacement controls:

**ES** - Electric motor displacement control

**HG** - Handwheel displacement control (Special feature)

**FE** - Screw adjustment control (Special feature)

**DP** - Pressure signal displacement control

**SP** - Electro hydraulic displacement control

### Typical section of MFX motor

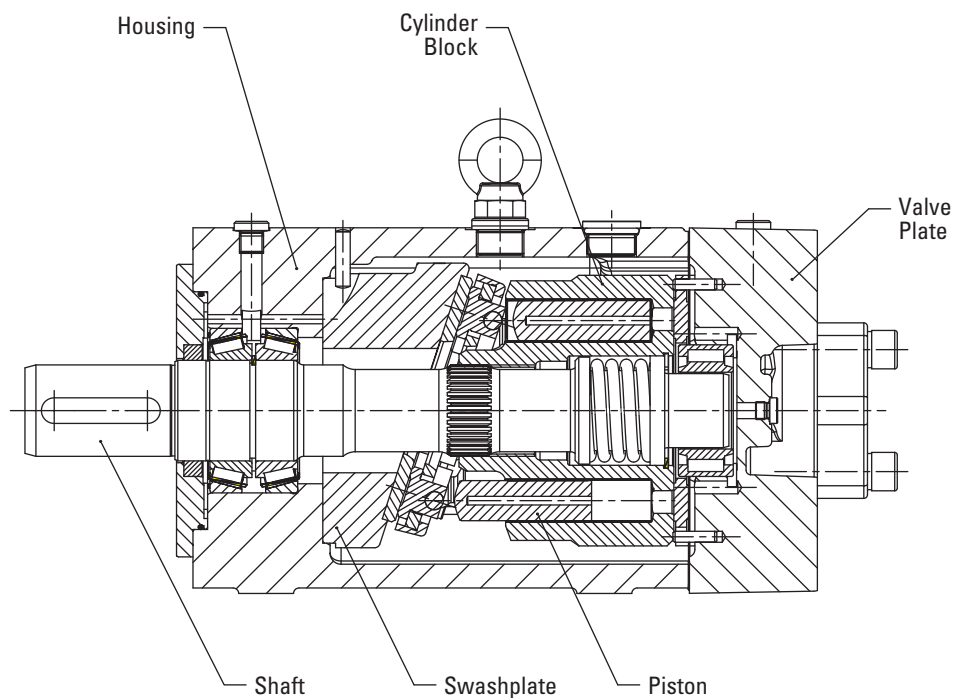

Dimensional information listed in this catalog is subject to change without notice.

# Model Code

Fixed & Variable  
Displacement Motors

"X" Series

## Form Page

The following 42-digit coding system has been developed to identify all of the configuration options for the "X" series fixed and variable displacement motors. Use this model code to specify a unit with the desired features. All 42-digits must be present when ordering. You may want to photocopy the matrix below to ensure, that each number is entered in the correct box. If adjustments other than the standard setting (character 34... 37) or special features (character 38 ... 40) are needed, please provide the information when ordering.

Some characters are already filled out. For such characters there is no option available.

Explanation for each character can be found as follows:

	<b>CHARACTER</b>	<b>PAGE</b>
Basic Motor Model Code	1.....22	5
Control Options	23.....33	6-11
Customer Adjustment Specification	34.....37	6-11
Special Features	38.....40	12
Design Number	41.....42	12

1	2	3	4	5	6	7	8	9	10	11	12	13	14	15	16	17	18	19	20	21	22
M		X	S	-				M			B			1	R			S	V		A
23	24	25	26	27	28	29	30	31	32	33	34	35	36	37	38	39	40	41	42		
																				1	0

### SPECIFY NON STANDARD ADJUSTMENT BELOW

---

---

---

---

---

---

---

---

---

---

---

---

---

---

---

---

---

---

---

---

---

---

---

---

---

---

---

---

---

---

### SPECIFY SPECIAL FEATURE BELOW

---

---

---

---

---

---

---

---

---

---

---

---

---

---

---

---

---

---

---

---

---

---

---

---

---

---

---

---

---

---

# Model Code

## Motors

### "X" Series - Basic Motor

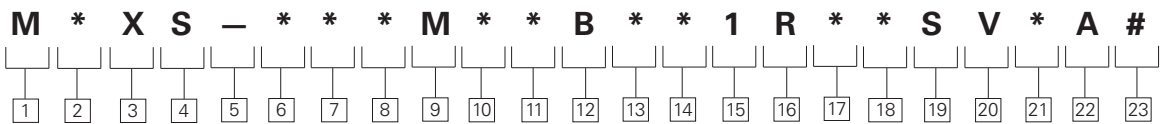

**1 Motor**

**M** – Motor

**2 Displacement**

**F** – Fixed Displacement  
**V** – Variable Displacement

**3 Pump Series**

**X** – “X” Series  
(was 20 design)

**4 Configuration**

**S** – Single Unit

**5 Separator**

– Separator

**6 7 8 Displacement**

**Size**

**066** – 66 cm<sup>3</sup>/r [4.0 in<sup>3</sup>/rev]  
**090** – 90 cm<sup>3</sup>/r [5.5 in<sup>3</sup>/rev]  
**130** – 130 cm<sup>3</sup>/r [7.9 in<sup>3</sup>/rev]  
**180** – 180 cm<sup>3</sup>/r [11.0 in<sup>3</sup>/rev]  
**250** – 250 cm<sup>3</sup>/r [15.3 in<sup>3</sup>/rev]  
(for Spares only)  
**???** – Non-Standard  
Displacement  
(MFX Only)

**9 Basic Standard**

**M** – Metric

**10 11 Mounting Flange**

**02** – ISO 3019/2-125A2HW  
**04** – ISO 3019/2-160A2HW  
**06** – ISO 3019/2-200A2HW  
See Chart Below

**12 Rotation Direction**

**B** – Both

**13 Adjustment Stops**

**0** – No Stop  
**4** – Mechanical Adjustment  
Stop Side A (MVX only)  
**5** – Mechanical Adjustment  
Stop Side B (MVX only)  
**6** – Mechanical Adjustment  
Stops Side A and B  
(MVX only)

**NOTE:**

**4** is used as max.  
Adjustment on Side A.  
**5** is used as min.  
Adjustment stop side A.  
When **0** is specified, min.  
Adjustment Stop is set  
at 35 % of Vgmax  
**6** is the combination  
of **4** and **5** together

**14 Thru-Drive Options**

**0** – None  
**K** – Tachogenerator  
**E** – Speed Limit Switch  
(Two Switches)

**15 Main Ports**

**1** – SAE Ports - Metric Bolts

**16 Main Port Orientation**

**R** – Radial (Side Ports)

**17 18 Main Drive Shaft End**

**01** – ISO Straight Key  
**02** – ISO Spline

**19 Drive Shaft Seal Configuration**

**S** – Single Shaft Seal

**20 Seal Material**

**V** - Viton\*  
\*Viton is a trademark of  
E.I. Dupont (other materials  
available, contact your  
Eaton Representative)

**21 Yoke Position Indicator**

**0** – No Position Indicator  
**V** – Visual Position Indicator  
**P** – Position Sensor  
**M** – Sensor with  
Visual Indicator

**22 Surface Finish**

**A** – Blue Painted  
Other options on special  
request available. Contact  
Eaton Sales.

**23 Add Control Model**

**Code** – Code (characters  
23...37) on the following  
pages

MOUNTING FLANGE OPTIONS AVAILABLE	066	090	130	180	250
ISO 3019/2-125A2HW	18	19			
ISO 3019/2-160A2HW			20	21	
ISO 3019/2-200A2HW					22

# Model Code

## Motors

"X" Series - No Control

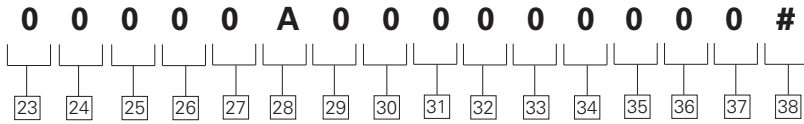

**23 24 Control Type**

**00** – No Control  
(for MFW only)

**25 Displacement Adjustment Options**

**0** – Not Applicable

**26 27 Electronic Controls**

**00** – Not Required

**28 Yoke Displacement Zone**

**A** – Single Side of Center "A"

**29 Extra Functions**

**0** – Not Required

**30 Pressure Control Options**

**0** – Not Applicable

**31 Position Monitoring**

**0** – No Position Monitoring

**32 Electric Motor Type**

**0** – No Electric Motor

**33 Control Voltage**

**0** – Not Applicable

**34 35 36 37 Customer Adjustment Specification**

**0000** – None

**38 Special Features**

Add special feature description (characters 44...46) on page 12 if required.

# Model Code

## Motors

"X" Series - ES Control

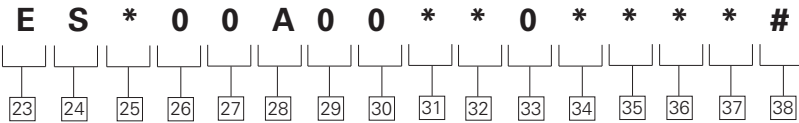

**23 24 Control Type**

**ES** – Electric Motor Displacement Control

**25 Displacement Adjustment Options**

- M** – Electric Motor - (Fast Response)
- N** – Electric Motor - (Medium Response)
- P** – Electric Motor - (Slow Response)

**26 27 Electronic Controls**

**00** – Not Required

**28 Yoke Displacement Zone**

**A** – Single Side of Center "A"

**29 Extra Functions**

**0** – Not Required

**30 Pressure Control Options**

**0** – Not Applicable

**31 Position Monitoring**

- A** – 4 Limit Switches
- B** – 8 Limit Switches
- P** – 4 Limit Switches + Sensor
- T** – 8 Limit Switches + Sensor

**32 Electric Motor Type**

- 2** – Motor with Brake (IP-54)
- 3** – Motor without Brake (Explosion Proof)

**33 Control Voltage**

**0** – Not Applicable

**34 35 36 37 Customer Adjustment Specification**

**0000** – None  
**????** – Yes (final number will be assigned by Eaton. Specify on table below)

**38 Special Features**

Add special feature description (characters 38...42) on page 12 if required.

**CUSTOMER ADJUSTMENT SPECIFICATIONS**

		Unit	Standard Adjustment	Customer Specified Adjustment	Remarks
All Revolution Adjustments Set at		rpm	1500	—	
Mech. Stop Side A (Used as Max. Adjustment Stop Side A)		cm <sup>3</sup> /rev	Vg <sub>max</sub>		
Mech. Stop Side B (Used as Max. Adjustment Stop Side A)		cm <sup>3</sup> /rev	35 5/8 Vg <sub>max</sub>		< 35% not possible
Displacement Adjusted to		cm <sup>3</sup> /rev	60% Vg <sub>max</sub>		
Position Monitoring Switch	1	cm <sup>3</sup> /rev	35% Vg <sub>max</sub>		< 35% not possible
	2	cm <sup>3</sup> /rev	95% Vg <sub>max</sub>		> 95% not possible
	3	cm <sup>3</sup> /rev	—		
	4	cm <sup>3</sup> /rev	—		
	5	cm <sup>3</sup> /rev	—		
	6	cm <sup>3</sup> /rev	—		
	7	cm <sup>3</sup> /rev	—		
	8	cm <sup>3</sup> /rev	—		

# Model Code

## Motors

"X" Series - HG Control

<b>H</b>	<b>G</b>	<b>0</b>	<b>0</b>	<b>0</b>	<b>A</b>	<b>0</b>	<b>0</b>	<b>0</b>	<b>0</b>	<b>0</b>	<b>*</b>	<b>*</b>	<b>*</b>	<b>*</b>	<b>#</b>
[23]	[24]	[25]	[26]	[27]	[28]	[29]	[30]	[31]	[32]	[33]	[34]	[35]	[36]	[37]	[38]

**[23][24] Control Type**

**HG** – Handwheel Displacement Control

**[25] Displacement Adjustment Options**

**0** – Not Applicable

**[26][27] Electronic Controls**

**00** – Not Required

**[28] Yoke Displacement Zone**

**A** – Single Side of Center "A"

**[29] Extra Functions**

**0** – Not Required

**[30] Pressure Control Options**

**0** – Not Applicable

**[31] Position Monitoring**

**0** – No Position Monitoring

**[32] Electric Motor Type**

**0** – No Electric Motor

**[33] Control Voltage**

**0** – Not Applicable

**[34][35][36][37] Customer Adjustment Specification**

**0000** – None

**????** – Yes (final number will be assigned by Eaton. Specify on table below)

**[38] Special Features**

Add special feature description (characters 38..42) on page 12 if required.

**CUSTOMER ADJUSTMENT SPECIFICATIONS**

	Unit	Standard Adjustment	Customer Specified Adjustment	Remarks
All Revolution Adjustments Set at	rpm	1500	—	
Displacement Adjusted to	cm <sup>3</sup> /rev	V <sub>gmax</sub>		



# Model Code

## Motors

"X" Series - FE Control

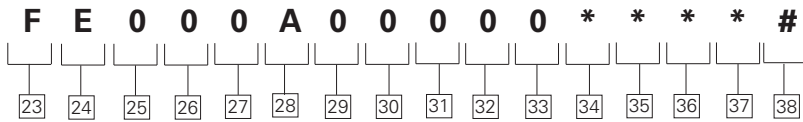

**23 24 Screw Adjustment Displacement Control**

FE – Screw Adjustment Displacement Control

**25 displacement Adjustment Options**

0 – Not Applicable

**26 27 Electronic Controls**

00 – Not Required

**28 Yoke Displacement Zone**

A – Single Side of Center "A"

**29 Extra Functions**

0 – Not Required

**30 Pressure Control Options**

0 – Not Applicable

**31 Position Monitoring**

0 – No Position Monitoring

**32 Electric Motor Type**

0 – No Electric Motor

**33 Control Voltage**

0 – Not Applicable

**34 35 36 37 Customer Adjustment Specification**

0000 – None

???? – Yes (final number will be assigned by Eaton. Specify on table below)

**38 Special Features**

Add special feature description (characters 38..42) on page 12 if required.

**CUSTOMER ADJUSTMENT SPECIFICATIONS**

	Unit	Standard Adjustment	Customer Specified Adjustment	Remarks
All Revolution Adjustments Set at	rpm	1500	—	
Displacement Adjusted to	cm <sup>3</sup> /rev	Vg <sub>max</sub>		

# Model Code

## Motors

"X" Series - DP Control

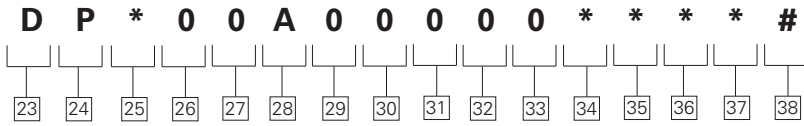

**23 24 Control Type**

**DP** – Pressure Signal Adjustment  
Displacement Control

**25 Displacement**

**Adjustment Options**

**G** – Mounting Interface  
Cetop 3 Only  
**H** – Remote Port G 1/4  
**J** – Proportional Relief inc.  
Electronics

**26 27 Electronic Controls**

**00** – Not Required

**28 Yoke Displacement Zone**

**A** – Single Side of Center "A"

**29 Extra Functions**

**0** – Not Required

**30 Pressure Control Options**

**0** – Not Applicable

**31 Position Monitoring**

**0** – No Position Monitoring

**32 Electric Motor Type**

**0** – No Electric Motor

**33 Control Voltage**

**0** – Not Applicable

**34 35 36 37 Customer Adjustment Specification**

**0000** – None  
**????** – Yes (final number will be assigned by Eaton. Specify on table below)

**38 Special Features**

Add special feature description (characters 38...42) on page 12 if required.

**CUSTOMER ADJUSTMENT SPECIFICATIONS**

	Unit	Standard Adjustment	Customer Specified Adjustment	Remarks
All Revolution Adjustments below set at ..	rpm	1500	—	
Pilot Pressure for Size 250 & 360 (External)	bar	60	—	
Pilot Pressure for Size 500 & 750 (External)	bar	80	—	
Mech. Stop Side A (used as max Adjustment Stop Side A)	cm <sup>3</sup> /rev.	Vg <sub>max</sub>		
Mech. Stop Side B (used as min Adjustment Stop Side A)	cm <sup>3</sup> /rev.	35% of Vg <sub>max</sub>		<35% not possible

# Model Code

## Motors

"X" Series - SP Control

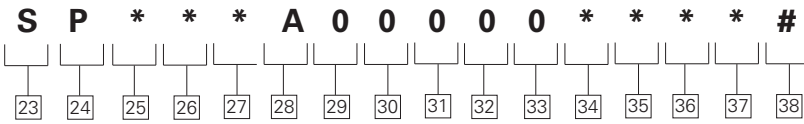

**23 24 Control Type**

**SP** – Proportional Valve Displacement Control

**25 Displacement Adjustment Options**

**C** – With CETOP 3 Prop Valve KDG4V 3  
**F** – With CETOP 5 Prop Valve

**26 27 Electronic Controls**

03 – ER 9.3 - 10 (CETOP 3)  
 04 – ER 9.4 - 10 (CETOP 5)

**28 Yoke Displacement Zone**

**A** – Single Side of Center "A"

**29 Extra Functions**

**0** – Not Required

**30 Pressure Control Options**

**0** – Not Applicable

**31 Position Monitoring**

**0** – No Position Monitoring

**32 Elec Motor Type**

**0** – No Electric Motor

**33 Control Voltage**

**0** – Not Applicable

**34 35 36 37 Customer Adjustment Specification**

**0000** – None  
**????** – Yes (final number will be assigned by Eaton. Specify on table below)

**38 Special Features**

Add special feature description (characters 38..40) on page 12 if required.

**\*CUSTOMER ADJUSTMENT SPECIFICATIONS**

	Unit	Standard Adjustment	Customer Specified Adjustment	Remarks
All Revolution Adjustments below set at ..	rpm	1500	—	
Pilot Pressure	bar	60	—	
Mech. Stop Side A (used as max Adjustment Stop Side A)	cm <sup>3</sup> /rev.	Vg <sub>max</sub>		
Mech. Stop Side B (used as min Adjustment Stop Side B)	cm <sup>3</sup> /rev.	35% of Vg <sub>max</sub>		
Max. Stop by Control Side A	cm <sup>3</sup> /rev.	95% of Vg <sub>max</sub>	EI Card Adjustment done by customer	Refer to EI card Manual
Min. Stop by Control Side A	cm <sup>3</sup> /rev.	35% of Vg <sub>max</sub> +/-2.5%	EI Card Adjustment done by customer	Refer to EI card Manual
Ramp Time 0 → A For 100% Stroke	sec	0	EI Card Adjustment done by customer	Refer to EI card Manual
Ramp Time A → 0 For 100% Stroke	sec	0	EI Card Adjustment done by customer	Refer to EI card Manual
Preset Input Signals S1....S4	L/min	—	EI Card Adjustment done by customer	Refer to EI card Manual

# Model Code

## Motors

### "X" Series - Special Features

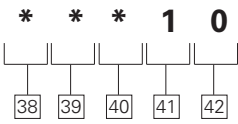

#### 38 39 40 Special Features

000 – None

??? – Defined by Eaton

---

#### 41 42 Design Number

10 – Design Number

# Motor Specifications - U.S.

MODEL			MFW / MVW 66	MFW / MVW 90	MFW / MVW 130	MFW / MVW 180
Design			swashplate type			
Type of mounting			Flange- or foot-mounted. Combination units foot mounted only.			
Pipe connection SAE Flange	B A	psi	1" = 6000 1" = 6000	1" = 6000 1" = 6000	1" = 6000 1" = 6000	1 1/4" = 6000 1 1/4" = 6000
Direction of rotation			Bi - directional			
Speed range	$n_{min}^{1)}$ $n_{max}^{2)}$	rpm	80 1800			
Installation position			Optional, see mounting information			
Ambient temperature range	min max	°F	-4 122			
Weight	M	lbs.	121	165	234	251
Mass of inertia	J	lb ft <sup>2</sup>	0.38	0.38	1.068	1.068

## HYDRAULIC CHARACTERISTICS

Nominal pressure (100% duty cycle)	$p_N$	psi	5000			
Output pressure	$p_{Amin} / p_{Bmin}$ $p_{Bmax} / p_{Amax}$	psi	30 Pressure can be applied to the motor outlet but the sum of $p_{Amax}$ and $p_{Bmax}$ must not exceed the maximum value of 6090psi			
Maximum pressure to DIN 24312	$p_{max}$	psi	6090			
Hydraulic fluid			Hydraulic oil to DIN 51524 part 2. Refer to section Application Data-Fluid Recommendations			
Hydraulic fluid temperature range	min max	°F	-13 (on startup) 194			
Viscosity range for continuous operation	min max	cSt cSt	10 75			
Maximum permissible start viscosity	max	cSt	1000			
Filtering	ISO 4406		18/15/13			
Maximum geometric absorption rate <sup>3)</sup>	$V_{gmax}$	in <sup>3</sup>	4.1	5.5	7.9	11.0
Minimum geometric absorption rate	$V_{gmin}$	in <sup>3</sup>	When no minimum adjustment stop is specified, min. geometric absorption rate is set at 35% of $V_{gmax}$			
Maximum geometric motor flow	$Q_g$	USgpm	31.4	42.8	61.8	85.6
Case pressure	$p_{Vmax}$	psi	max. 7.2psi over $p_{Amin} / p_{Bmin}$ , $p_{Vmax} = 58$ psi abs., $p_{Vmax} = 87$ psi abs. with special shaft seal			

## DRIVE

Maximum driving torque - ( $p_{Amax}$ or $p_{Bmax}$ , $\eta = 100\%$ )	M1 single	lb.ft	325	444	640	887
Maximum power consumption - $n=1800$ rpm ( $p_{Amax}$ or $p_{Bmax}$ , $\eta = 100\%$ )	P1 single	hp	112	152	220	304

## COMBINATION UNITS

Maximum driving torque - comb. unit (splined shaft only)	M1	lb.ft	2x 325	2x 444	2x 640	2x 887
---	----	-------	--------	--------	--------	--------

- 1) Minimum speed for continuous operation
- 2) Higher speed available on request
- 3) Tolerance + 1%

# Motor Specifications - Metric

MODEL			MFW / MVW 66	MFW / MVW 90	MFW / MVW 130	MFW / MVW 180
Design			swashplate type			
Type of mounting			Flange or foot-mounted. Combination units foot mounted only.			
Pipe connection SAE Flange	B A	psi	1" = 6000 1" = 6000	1" = 6000 1" = 6000	1" = 6000 1" = 6000	1 1/4" = 6000 1 1/4" = 6000
Direction of rotation			Bi - directional			
Speed range	$n_{min}^{1)}$ $n_{max}^{2)}$	min <sup>-1</sup>	80 1800			
Installation position			Optional, see mounting information			
Ambient temperature range	min max	°C	-20 50			
Weight	M	kg	55	75	106	114
Mass of inertia	J	kg m <sup>2</sup>	0,016	0,016	0,045	0,045

## HYDRAULIC CHARACTERISTICS

Nominal pressure (100% duty cycle)	$p_N$	bar	350			
Output pressure	$p_{Amin} / p_{Bmin}$ $p_{Bmax} / p_{Amax}$	bar	2 Pressure can be applied to the motor outlet but the sum of $p_{Amax}$ and $p_{Bmax}$ must not exceed the maximum value of 420 bar			
Maximum pressure to DIN 24312	$p_{max}$	bar	420			
Hydraulic fluid			Hydraulic oil to DIN 51524 part 2. Refer to section Application Data-Fluid Recommendations			
Hydraulic fluid temperature range	min max	°C	-25 (on startup) 90			
Viscosity range for continuous operation	min max	cSt cSt	10 75			
Maximum permissible start viscosity	max	cSt	1000			
Filtering	ISO 4406		18/15/13			
Maximum geometric absorption rate <sup>3)</sup>	$V_{gmax}$	cm <sup>3</sup>	66	90	130	180
Minimum geometric absorption rate	$V_{gmin}$	cm <sup>3</sup>	When no minimum adjustment stop is specified, min. geometric absorption rate is set at 35% of $V_{gmax}$			
Maximum geometric motor flow	$Q_g$	l / min	119	162	234	324
Case pressure	$p_{vmax}$	bar	max. 0.5 bar over $p_{Amin} / p_{Bmin}$ , $p_{vmax} = 4$ bar abs., $p_{vmax} = 6$ bar abs. with special shaft seal			

## DRIVE

Maximum driving torque - single unit ( $p_{Amax}$ or $p_{Bmax}$ , $\eta = 100\%$ )	M1 Single	Nm	441	602	869	1203
Maximum power consumption - $n=180$ min <sup>-1</sup> ( $p_{Amax}$ or $p_{Bmax}$ , $\eta = 100\%$ )	P1 Single	kW	83	114	164	227

## COMBINATION UNITS

Maximum driving torque - comb. unit (splined shaft only)	M1	Nm	2x441	2x602	2x869	2x1203
---	----	----	-------	-------	-------	--------

1) Minimum speed for continuous operation

2) Higher speed available on request

3) Tolerance + 1%

# Electric Motor Displacement Control ES

"X" Series - Motors

This ES control adjusts the swashplate angle of the pump by means of a three phase electric servo motor, worm gearing and a switch box with 4 or (optional) 8 limit switches for different positions. A potentiometer for stepless adjustment and/or position monitoring is also available.

The response times from zero to maximum depends on the chosen ratio and the (fixed) speed of the servo motor (this means that once the control is defined and built the response times are not variable during operation).

Explosion protection versions are also available.

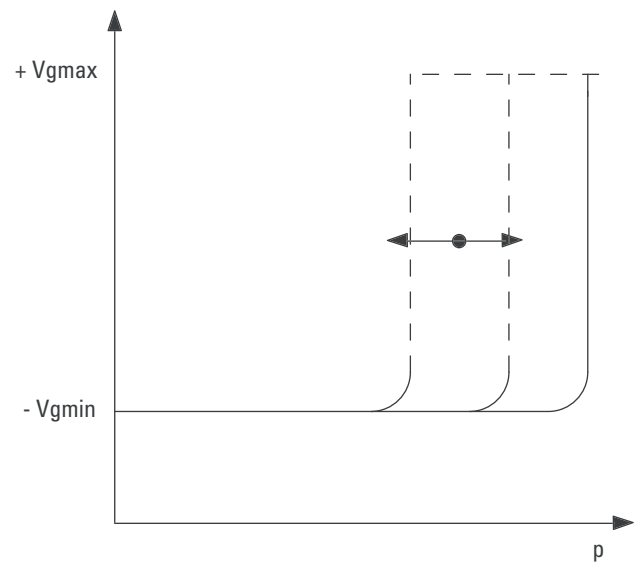
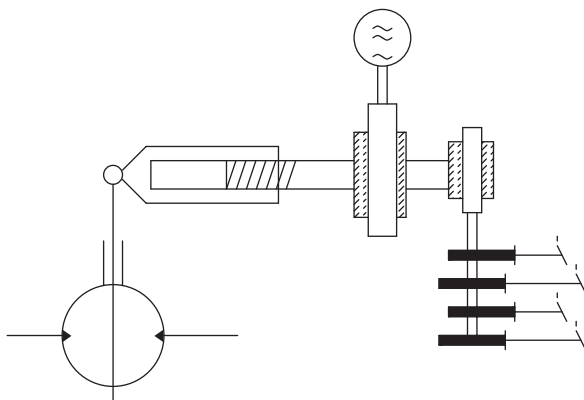
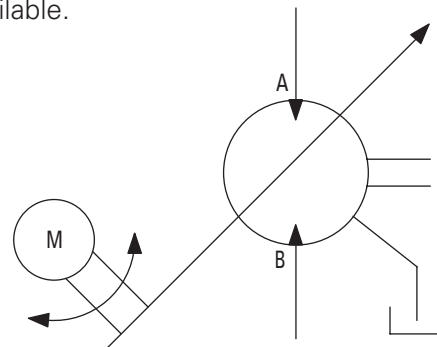

## MVX Response times ES - Control

Size	THEORETICAL RESPONSE TIME (SEC) FOR MAXIMUM DISPLACEMENT						CHARACTER IN MODEL CODE POS.25
	066 / 090		130 / 180		250		
Frequency Hz	50	60	50	60	50	60	
Fast	5	4	12	10	10	9	M
Medium	16	13	23	19	20	16	N
Slow	25	21	35	30	31	26	P

Response time from  $V_{gmin}$  (35%) to  $+V_{gmax}$  (100%)

# FE, HG Manual Adjustment Displacement Control

"X" Series - Motors

**FE** The FE control is a displacement control where the motor's swashplate angle is adjusted by a screw.

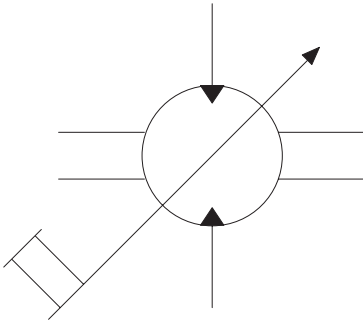

**HG** The HG control is a displacement control where the motor's swashplate angle can be adjusted by a handwheel.

The max. (and/or min.) swashplate angle can be limited by a spacer inside the control cylinder (pos. no. 13 in model coding, options 4, 5 or 6 in combination

with customer adjustment specification in position 34-37 for the set values). The setting must be defined before ordering and cannot be modified during operation.

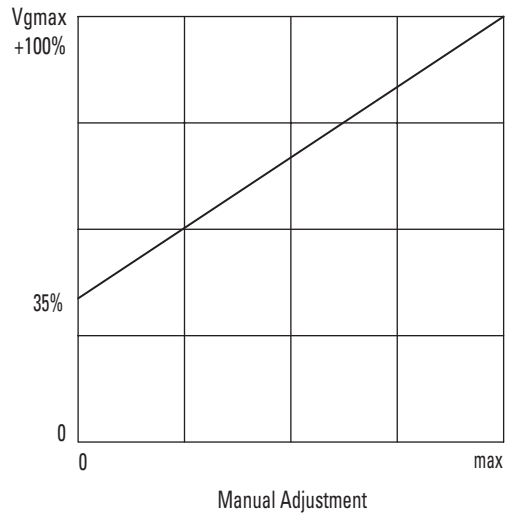



# DP Pressure Signal Adjustment Displacement Control

"X" Series - Motors

The swivel angle of the motor is proportional to the pilot pressure.

A separate pilot oil circuit is necessary. This circuit should be external to prevent the influence of variable motor speed to the pilot oil flow i.e. response time. From this the control pressure is reduced to the desired set value by means of a suitable pressure control valve (with P-T line) and throttle in P line 0.8 Ø (0.03 in).

The DP control can be used for stepless adjustment of the swashplate angle with standard requirements in dynamic and precision. No feedback signal is needed, an optical indicator recommended (pos. 21 in model coding, option "V").

The maximum swashplate angle of the motor can be limited mechanically to between 50% and 100% by a screw. As an additional option the max. (and/or min.) value can be limited by a spacer inside the control cylinder (pos. no. 13 in model coding, options 4, 5 or 6 in combination with customer adjustment specification in position 34-37 for the set values).

This solution is also recommended for very rough operating conditions and the need of a very exact repeatability over a long time period. The setting must be defined before ordering and cannot be modified during operation.

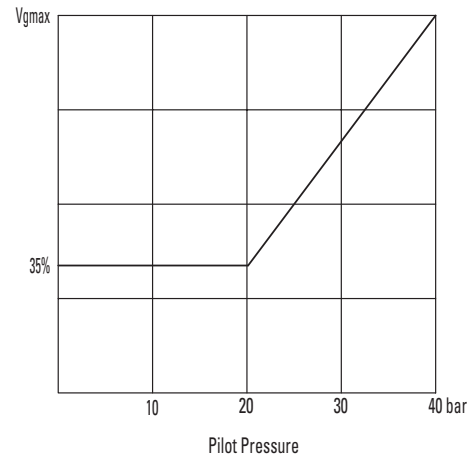
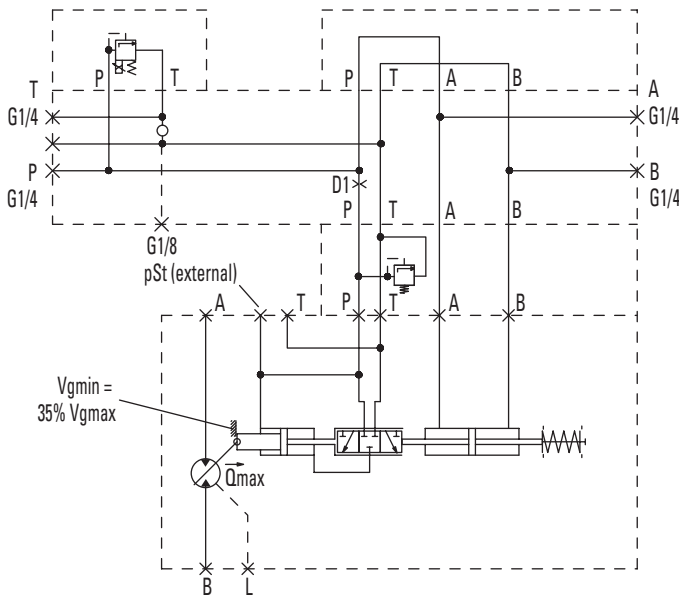

SIZE	RESPONSE TIME (SEC) WITH 12 L/MIN PILOT OIL FLOW (STANDARD)	PILOT PRESSURE PST (BAR)
066/090	0,5	60
130/180	0,7	60
250	0,9	60

Response time from Vgmin (35%) to +Vgmax (100%)

# Electrohydraulic Servo Adjustment "SP"

"X" Series - Motors

The Electro hydraulic displacement control works without throttle losses within electrically adjustable limits. This is done by controlling swashplate angle with electrical feedback (electrical closed loop control). A separate pilot oil circuit is necessary. This circuit should be external to prevent the influence of variable

motor speed to the pilot oil flow i.e. response time. The swashplate angle is recorded as an electrical signal and lead back to the control card. The proportional valve and servo piston transform the output signal of the control card to the desired setting. This results in very precise and dynamic control.

Hysteresis, consistency: approximately 1% of end value.

The maximum swashplate angle of the motor can be limited mechanically to between 50% and 100% by screw. As an additional option the max. (and/or min.) flow can be limited by a spacer inside the control cylinder (pos. no. 13 in model coding, options 4, 5 or 6 in

combination with customer adjustment specification in position 40-43 for the set values). This solution is also recommended for very rough operating conditions and the need for very exact repeatability over a long time period. The setting must be defined before ordering and cannot be modified during operation.

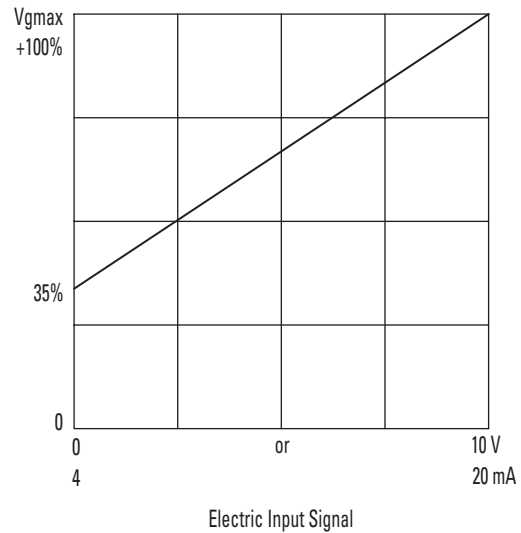
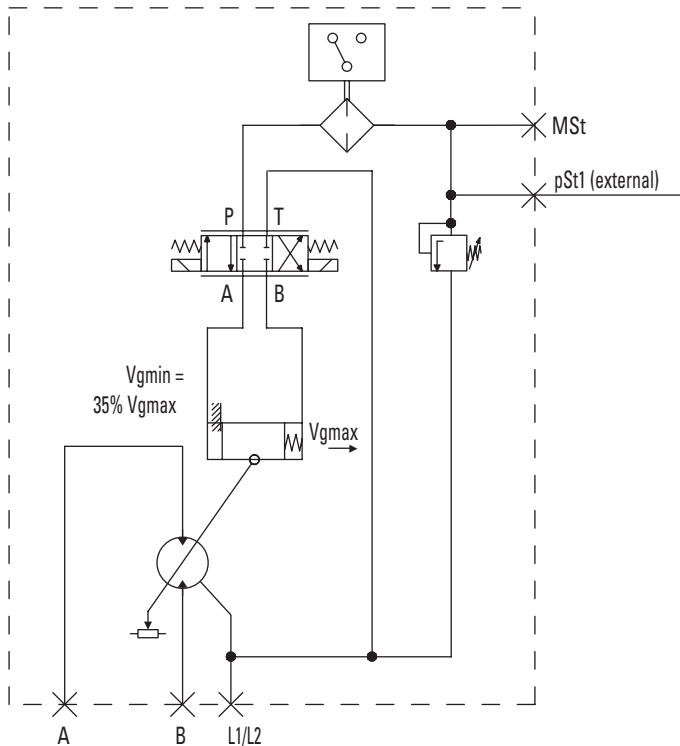

# Electrohydraulic Servo Adjustment "SP" (Cont.)

"X" Series - Motors

## Response Times - Electronic Control Cards

PROPORTIONAL VALVE	PILOT OIL FLOW L/MIN (USGPM)	PILOT OIL PRESSURE PST BAR (PSI)	CONTROL ELECTRONICS (AMP. CARD)	RESPONSE	UNIT SIZE CM <sup>3</sup>	SERVO PISTON DIAMETER MM (IN)	STROKE MM (IN)	VOLUME CM <sup>3</sup> (IN <sup>3</sup> ) PER CHAMBER
				TIME VMIN< >VMAX [MS]				
Medium response		60 (857)		170	066 / 090	40 / 30 (1.57 / 1.18)	18 (.71)	10,0 (.611)
KDG4V3-2 C20NMMUH760 (CETOP3)	12 (3.17)	60 (857)	ER9.3-10	230	130 / 180	55 / 38 (2.16 / 1.49)	23 (.89)	28,3 (1.725)
High response (CETOP5)	On request	60 (857)		375	250	70 / 50 (2.76 / 1.97)	28 (1.11)	52,6 (3.213)

The ER9.3-10 and ER 9.4-10 (for High Response) digital Amplifier cards are optimized for use with the SP - Control. Please ask for separate Documentation. Software is available for parameter setting and storing (database function). Contact Eaton to request free of charge manual and software CD.

# Dimensions - MFXS 066, 090, 130, 180

- L1 Drainage resp. filling of the housing
- MA Gauge port G1/4"
- MB Gauge port G1/4"

## Non-Standard Displacement:

SIZE	REDUCED DISPLACEMENT AVAILABLE
066	55 or 44 ccm / rev
090	75 or 60 ccm / rev
130	115 or 94 ccm / rev
180	160 or 130 ccm / rev

DIRECTION OF ROTATION	INLET PORT (HIGH PRESSURE SIDE)	OUTLET PORT (LOW PRESSURE SIDE)
Right Hand Rotation	B	A
Left Hand Rotation	A	B

SIZE	SAE-FLANGE 6000PSI
066	1"
090	1"
130	1"
180	1 1/4"

SIZE	B1	B2	B3	B4	B6	B7 h9
066	210	175	120	155	180	10
090	210	175	120	155	180	10
130	260	240	150	200	224	14
180	260	240	150	200	224	14

SIZE	D1 h8	D2 k6	D3	D4	D5	D6 Light Execution	D7 DEEP	D8 DEEP	D9	D10	D11	D12	D13
066	125	38	M12	18	M10	M26x1.5	M10 20	M12 18	25	R1/4"	W40x1.25x10a	R1/4"	M26x1.5
090	125	38	M12	18	M10	M26x1.5	M10 20	M12 18	25	R1/4"	W40x1.25x10a	R1/4"	M26x1.5
130	160	50	M16	22	M10	M26x1.5	M12 20	M12 20	25	R1/4"	W50x1.25x10a	R1/4"	11/16-12 UNF
180	160	50	M16	22	M10	M26x1.5	M12 20	M14 25	30	R1/4"	W50x1.25x10a	R1/4"	11/16-12 UNF

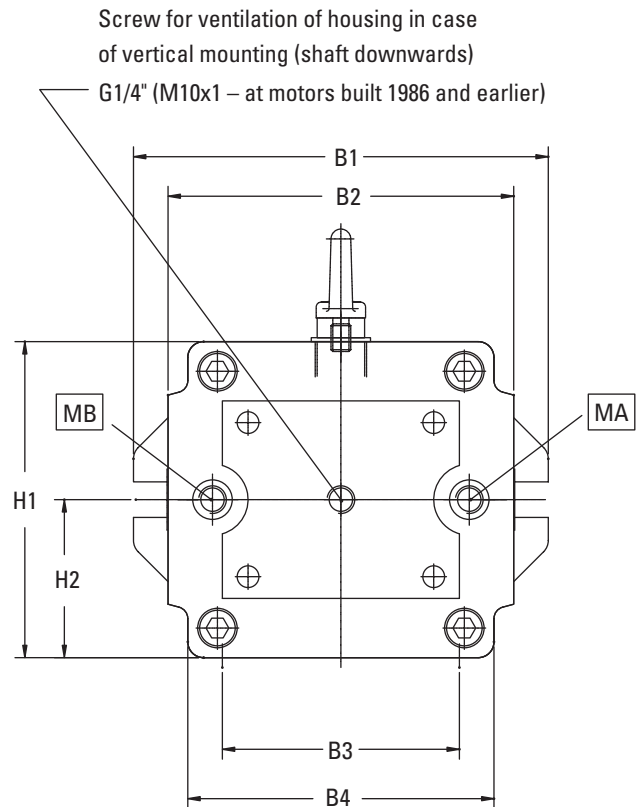

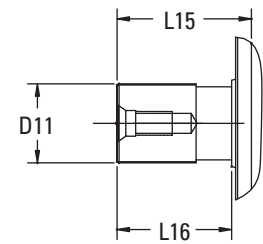
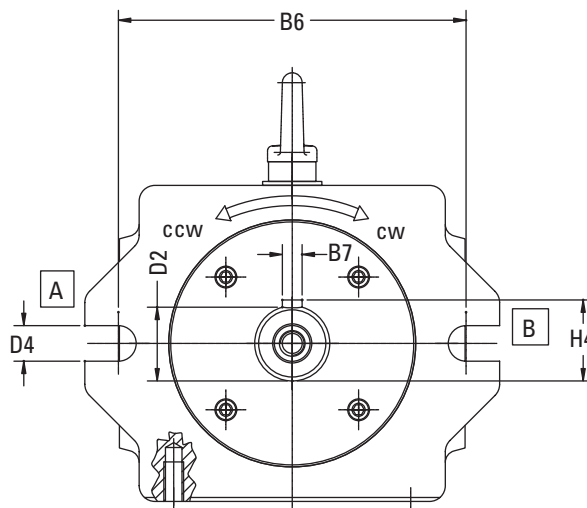
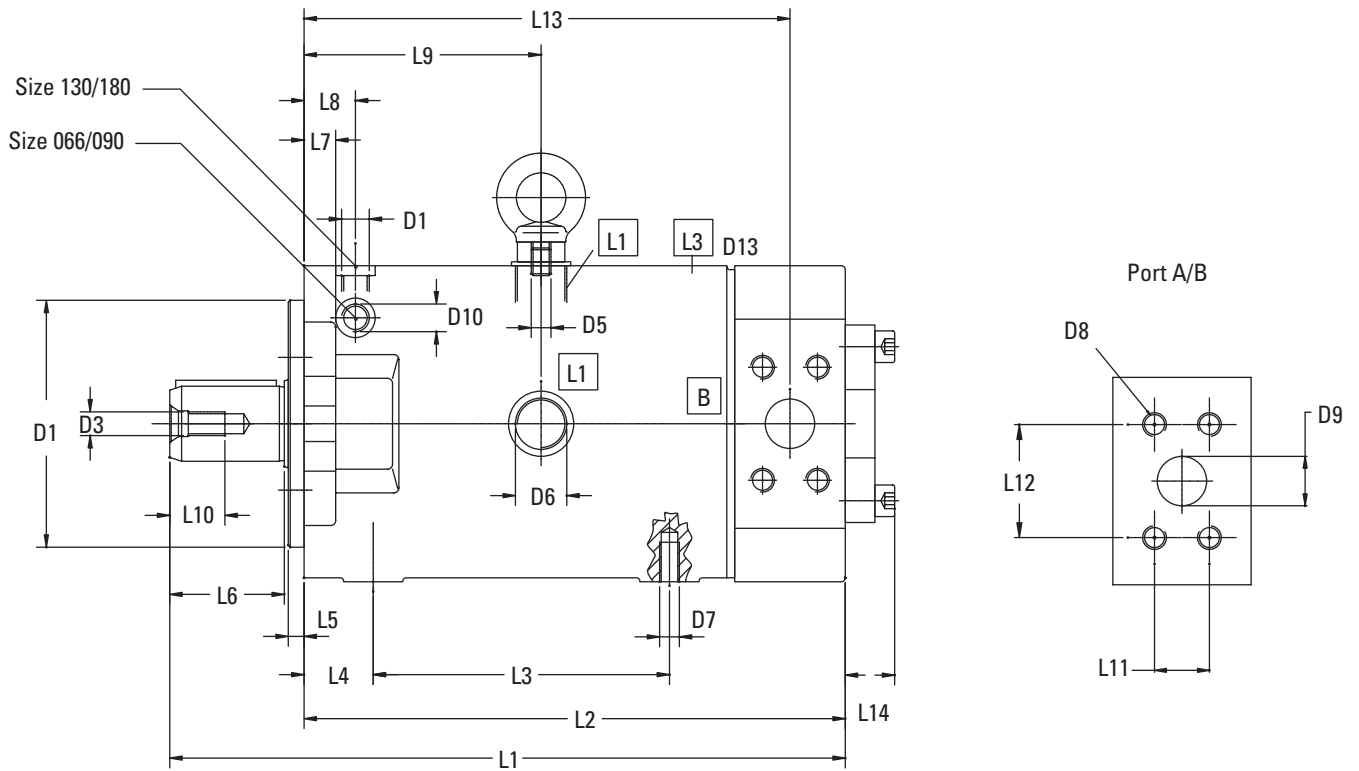

SIZE	H1	H2	H4
066	160	80	41
090	160	80	41
130	200	100	53.5
180	200	100	53.5

SIZE	L1	L2	L3	L4	L5	L6	L7	L8	L9	L10	L11	L12	L13	L14
066	342	274	150	35	8	58	16	26	120	28	27.8	57.2	246	—
090	342	274	150	35	8	58	16	26	120	28	27.8	57.2	246	—
130	433	341	185	40	9	82	20	32	148	36	27.8	57.2	306	26
180	433	341	185	40	9	82	20	32	148	36	31.8	66.7	306	26

# Dimensions - MVXS 066, 090, 130, 180

Displacement Control  
By Electric Motor, ES

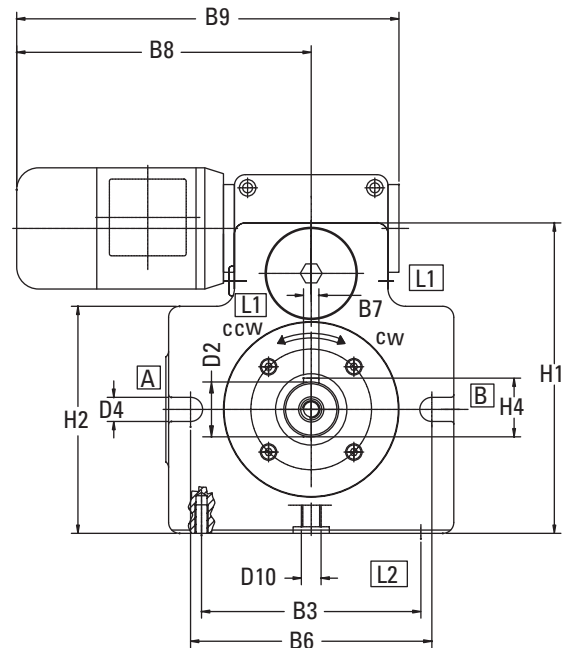
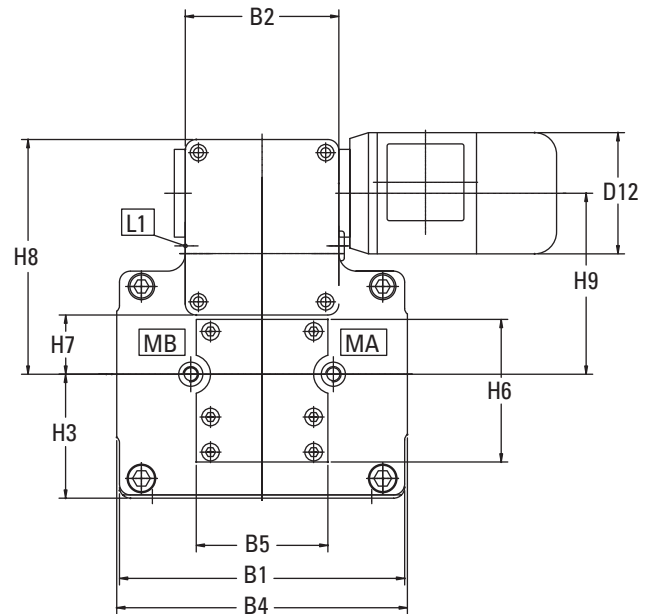

- L1 Two drain ports, one supplied plugged.
- L2 Supplementary drain or bleed plug. Must be drained in addition to L1 if the pump is installed with the shaft input end pointing upwards.
- L3 Oil filling or bleed plug. Must be drained in addition to L1 if the pump is installed with the shaft input end pointing downwards.
- MA Gauge port G1/4"
- MB Gauge port G1/4"

DIRECTION OF ROTATION	INLET PORT (HIGH PRESSURE SIDE)	OUTLET PORT (LOW PRESSURE SIDE)
Right Hand Rotation	B	A
Left Hand Rotation	A	B

SIZE	B1	B2	B3	B4	B5	B6	B7 h9	B8	B9
066	210	116	160	235	120	180	10	276.5	334.5
090	210	116	160	235	120	180	10	276.5	334.5
130	260	140	200	265	120	224	14	288.5	368.5
180	260	140	200	265	120	224	14	288.5	368.5

SIZE	D1 h8	D2 k6	D3	D4	D5	D6 Light Execution	D7 DEEP	D8 DEEP	D9	D10 DEEP	D11	D12	D13 SAEJ475
066	125	38	M12	18	M10	M22x1.5	M10 20	M12 18	25	M18x1.5 12	VW40x1.25x10a	110.5	7/8-14 UNF
090	125	38	M12	18	M10	M22x1.5	M10 20	M12 20	25	M18x1.5 12	VW40x1.25x10a	110.5	7/8-14 UNF
130	160	50	M16	22	M10	M26x1.5	M12 26	M12 20	25	M18x1.5 12	VW50x1.25x10a	110.5	11/16-12 UNF
180	160	50	M16	22	M10	M26x1.5	M12 26	M14 22	30	M18x1.5 12	VW50x1.25x10a	110.5	11/16-12 UNF

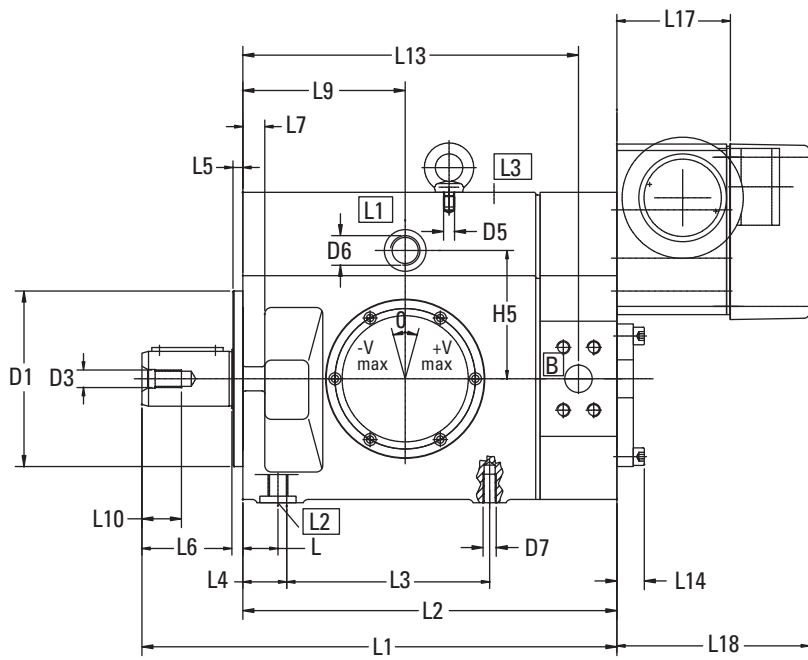

For Splined Data See Table

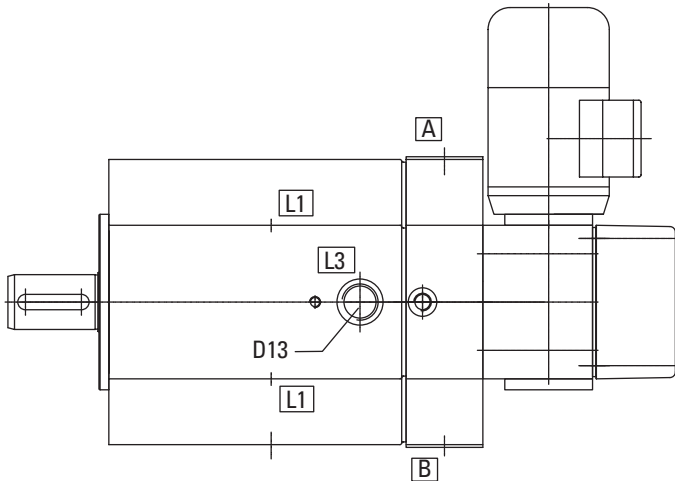
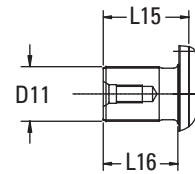

Port A/B

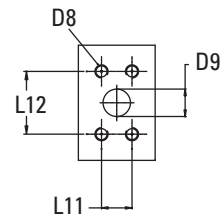

SIZE	H1	H2	H3	H4	H5	H6	H7	H8	H9
066	227	162	90	41	93	130	53	168	122
090	227	162	90	41	93	130	53	168	122
130	283	207	113	53.5	117	130	58.5	214	165
180	283	207	113	53.5	117	130	58.5	214	165

SIZE	L1	L2	L3	L4	L5	L6	L7	L8	L9	L10	L11	L12	L13	L14	L15	L16	L17	L18
066	342	274	150	35	8	58	16	26	120	28	27.8	57.2	245.6	25	68	58	78	153.5
090	342	274	150	35	8	58	16	26	120	28	27.8	57.2	245.6	25	68	58	78	153.5
130	433	341	185	40	9	82	20	32	148	36	27.8	57.2	306	26	78	68	100	175.5
180	433	341	185	40	9	82	20	32	148	36	27.8	57.2	306	26	78	68	100	175.5

# Dimensions - MVXS 066, 090, 130, 180

## Handwheel Control, HG

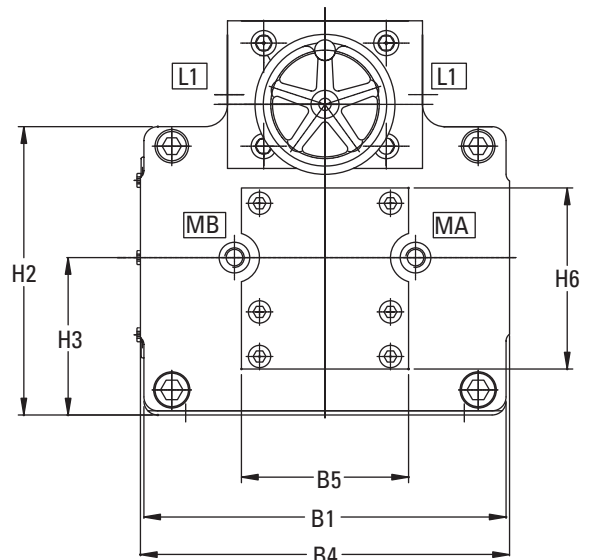

- L1 Two drain ports, one supplied plugged.
- L2 Supplementary drain or bleed plug. Must be drained in addition to L1 if the pump is installed with the shaft input end pointing upwards.
- L3 Oil filling or bleed plug. Must be drained in addition to L1 if the pump is installed with the shaft input end pointing downwards.
- MA Gauge port G1/4"
- MB Gauge port G1/4"

DIRECTION OF ROTATION	INLET PORT (HIGH PRESSURE SIDE)	OUTLET PORT (LOW PRESSURE SIDE)
Right Hand Rotation	B	A
Left Hand Rotation	A	B

SIZE	SAE-FLANGE 6000PSI
066	1"
090	1"
130	1"
180	1 1/4"

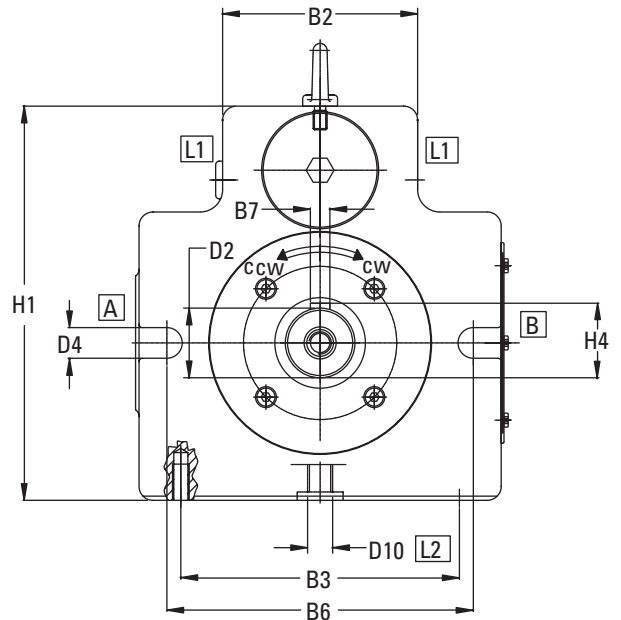

SIZE	B1	B2	B3	B4	B5	B6	B7 h9
066	210	116	160	235	120	180	10
090	210	116	160	235	120	180	10
130	260	140	200	265	120	224	14
180	260	140	200	265	120	224	14

SIZE	D1 h8	D2 k6	D3	D4	D5	D6 Light Execution	D7 DEEP	D8 DEEP	D9	D10 DEEP	D11	D12 SAEJ475
066	125	38	M12	18	M10	M22x1.5	M10 20	M12 18	25	M18x1.5 12	W40x1.25x10a	7/8-14 UNF
090	125	38	M12	18	M10	M22x1.5	M10 20	M12 20	25	M18x1.5 12	W40x1.25x10a	7/8-14 UNF
130	160	50	M16	22	M10	M26x1.5	M12 26	M12 20	25	M18x1.5 12	W50x1.25x10a	11/16-12 UNF
180	160	50	M16	22	M10	M26x1.5	M12 26	M14 22	30	M18x1.5 12	W50x1.25x10a	11/16-12 UNF



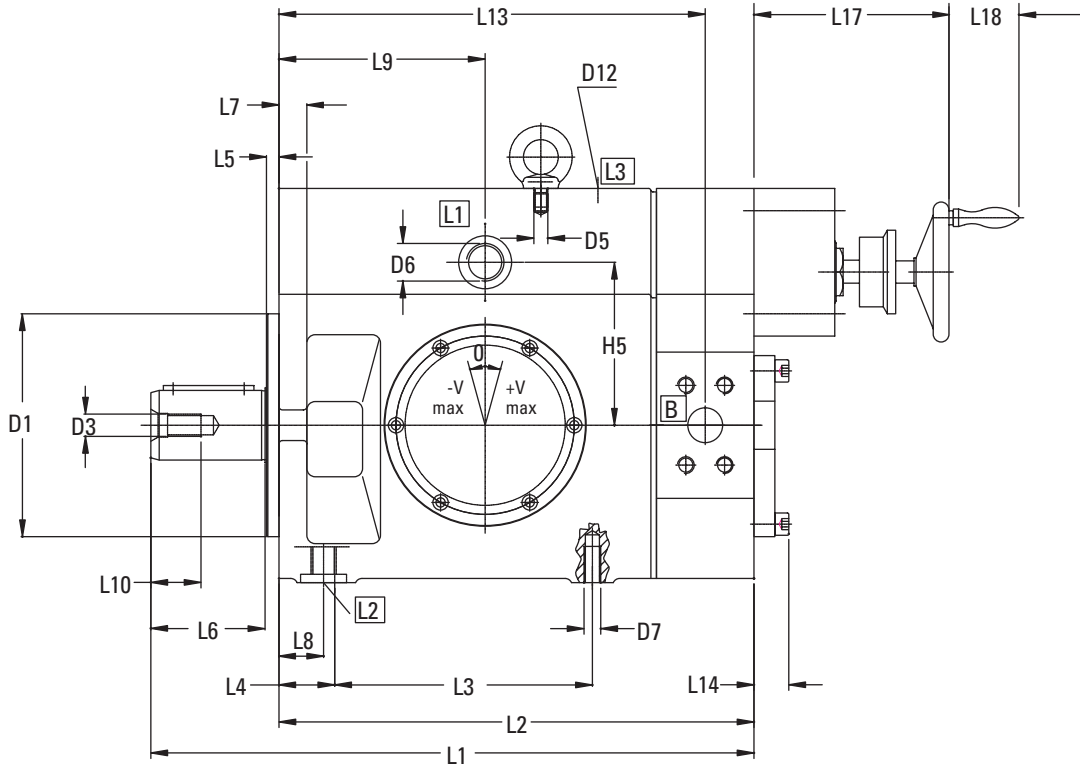

For Splined Data See Table

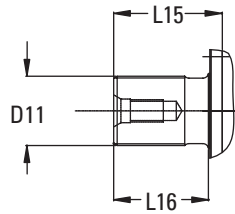

Port A/B

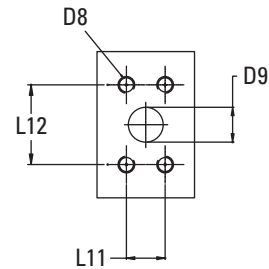

SIZE	H1	H2	H3	H4	H5	H6
066	227	162	90	41	93	130
090	227	162	90	41	93	130
130	283	207	113	53.5	117	130
180	283	207	113	53.5	117	130

SIZE	L1	L2	L3	L4	L5	L6	L7	L8	L9	L10	L11	L12	L13	L14	L15	L16	L17	L18
066	342	274	150	35	8	58	16	26	120	28	27.8	57.2	245.6	25	68	58	130	46
090	342	274	150	35	8	58	16	26	120	28	27.8	57.2	245.6	25	68	58	130	46
130	433	341	185	40	9	82	20	32	148	36	27.8	57.2	306	26	78	68	130	46
180	433	341	185	40	9	82	20	32	148	36	31.8	66.2	306	26	78	68	130	46

# Dimensions - MVXS 066, 090, 130, 180

## Adjustment Screw Control, FE

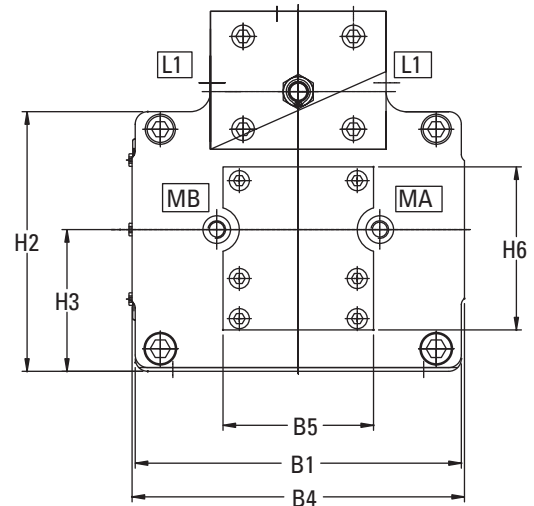

- L1 Two drain ports, one supplied plugged.
- L2 Supplementary drain or bleed plug. Must be drained in addition to L1 if the pump is installed with the shaft input end pointing upwards.
- L3 Oil filling or bleed plug. Must be drained in addition to L1 if the pump is installed with the shaft input end pointing downwards.
- MA Gauge port G1/4"
- MB Gauge port G1/4"

DIRECTION OF ROTATION	INLET PORT (HIGH PRESSURE SIDE)	OUTLET PORT (LOW PRESSURE SIDE)
Right Hand Rotation	B	A
Left Hand Rotation	A	B

SIZE	SAE-FLANGE 6000PSI
066	1"
090	1"
130	1"
180	1 1/4"

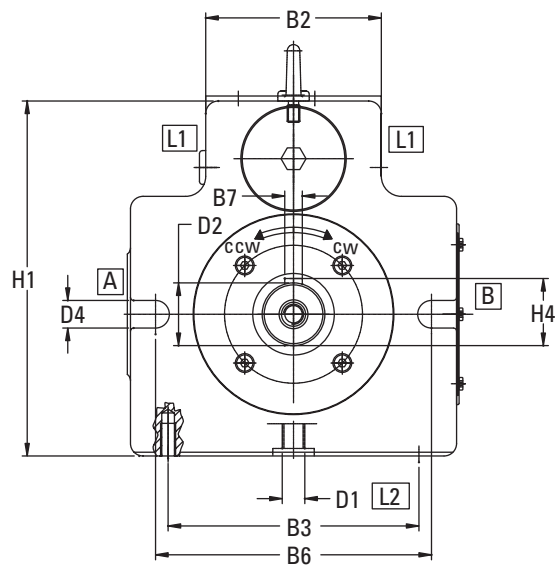

SIZE	B1	B2	B3	B4	B5	B6	B7 h9
066	210	116	160	235	120	180	10
090	210	116	160	235	120	180	10
130	260	140	200	265	120	224	14
180	260	140	200	265	120	224	14

SIZE	D1 h8	D2 k6	D3	D4	D5	D6 Light Execution	D7 DEEP	D8 DEEP	D9	D10 DEEP	D11	D12 SAEJ475
066	125	38	M12	18	M10	M22x1.5	M10 20	M12 18	25	M18x1.5 12	W40x1.25x10a	7/8-14 UNF
090	125	38	M12	18	M10	M22x1.5	M10 20	M12 20	25	M18x1.5 12	W40x1.25x10a	7/8-14 UNF
130	160	50	M16	22	M10	M26x1.5	M12 26	M12 20	25	M18x1.5 12	W50x1.25x10a	11/16-12 UNF
180	160	50	M16	22	M10	M26x1.5	M12 26	M14 22	30	M18x1.5 12	W50x1.25x10a	11/16-12 UNF

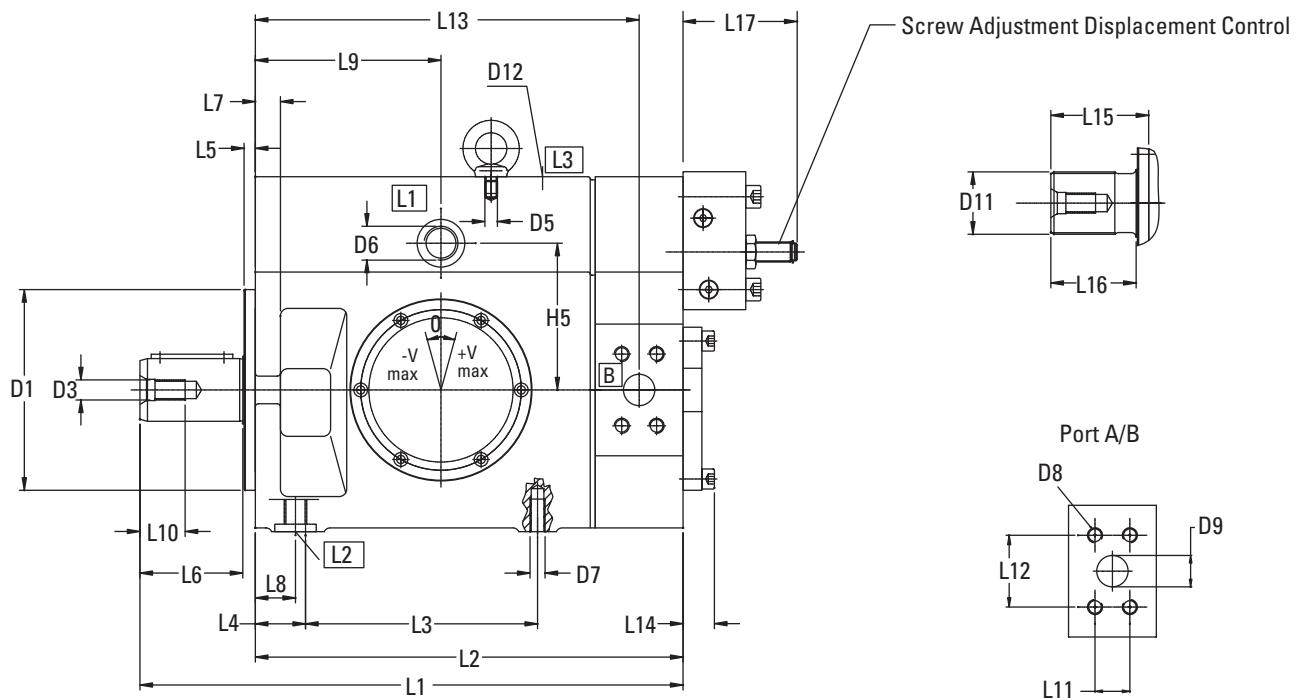

SIZE	H1	H2	H3	H4	H5	H6
066	227	162	90	41	93	130
090	227	162	90	41	93	130
130	283	207	113	53.5	117	130
180	283	207	113	53.5	117	130

SIZE	L1	L2	L3	L4	L5	L6	L7	L8	L9	L10	L11	L12	L13	L14	L15	L16	L17
066	342	274	150	35	8	58	16	26	120	28	27.8	57.2	245.6	25	68	58	90
090	342	274	150	35	8	58	16	26	120	28	27.8	57.2	245.6	25	68	58	90
130	433	341	185	40	9	82	20	32	148	36	27.8	57.2	306	26	78	68	90
180	433	341	185	40	9	82	20	32	148	36	31.8	66.2	306	26	78	68	90

# Dimensions - MVXS 066, 090, 130, 180

Pressure Signal  
Displacement Control, DP

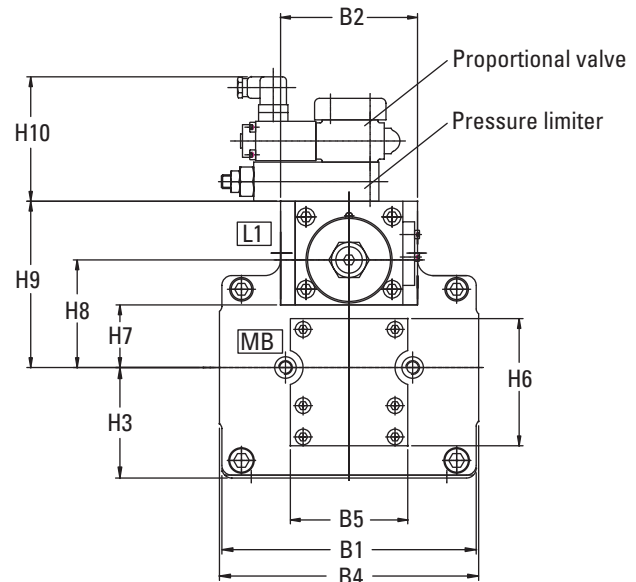

- T Return line of control circuit G1/2"
- L1 Two drain ports, one supplied plugged.
- L2 Supplementary drain or bleed plug. Must be drained in addition to L1 if the pump is installed with the shaft input end pointing upwards.
- L3 Oil filling or bleed plug. Must be drained in addition to L1 if the pump is installed with the shaft input end pointing downwards.
- MA Gauge port system pressure G1/4"
- MB Gauge port system pressure G1/4"

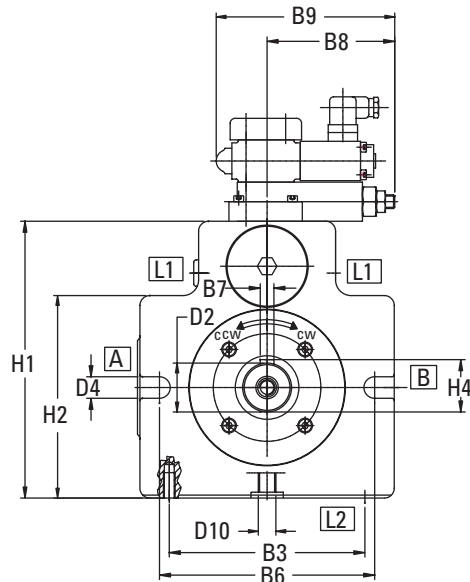

DIRECTION OF ROTATION	INLET PORT (HIGH PRESSURE SIDE)	OUTLET PORT (LOW PRESSURE SIDE)
Right Hand Rotation	B	A
Left Hand Rotation	A	B

SIZE	SAE-FLANGE 6000PSI
066	1"
090	1"
130	1"
180	1 1/4"

SIZE	B1	B2	B3	B4	B5	B6	B7 h9	B8	B9
066	210	116	160	235	120	180	10	130.5	182.5
090	210	116	160	235	120	180	10	130.5	182.5
130	260	140	200	265	120	224	14	130.5	182.5
180	260	140	200	265	120	224	14	130.5	182.5

SIZE	D1 h8	D2 k6	D3	D4	D5	D6 Light Execution	D7 DEEP	D8 DEEP	D9	D10 DEEP	D11	D12	D13 SAEJ475
066	125	38	M12	18	M10	M22x1.5	M10 20	M12 18	25	M18x1.5 12	W40x1.25x10a	64	7/8-14 UNF
090	125	38	M12	18	M10	M22x1.5	M10 20	M12 20	25	M18x1.5 12	W40x1.25x10a	64	7/8-14 UNF
130	160	50	M16	22	M10	M26x1.5	M12 26	M12 20	25	M18x1.5 12	W50x1.25x10a	88	1 1/16-12 UNF
180	160	50	M16	22	M10	M26x1.5	M12 26	M14 22	30	M18x1.5 12	W50x1.25x10a	88	1 1/16-12 UNF

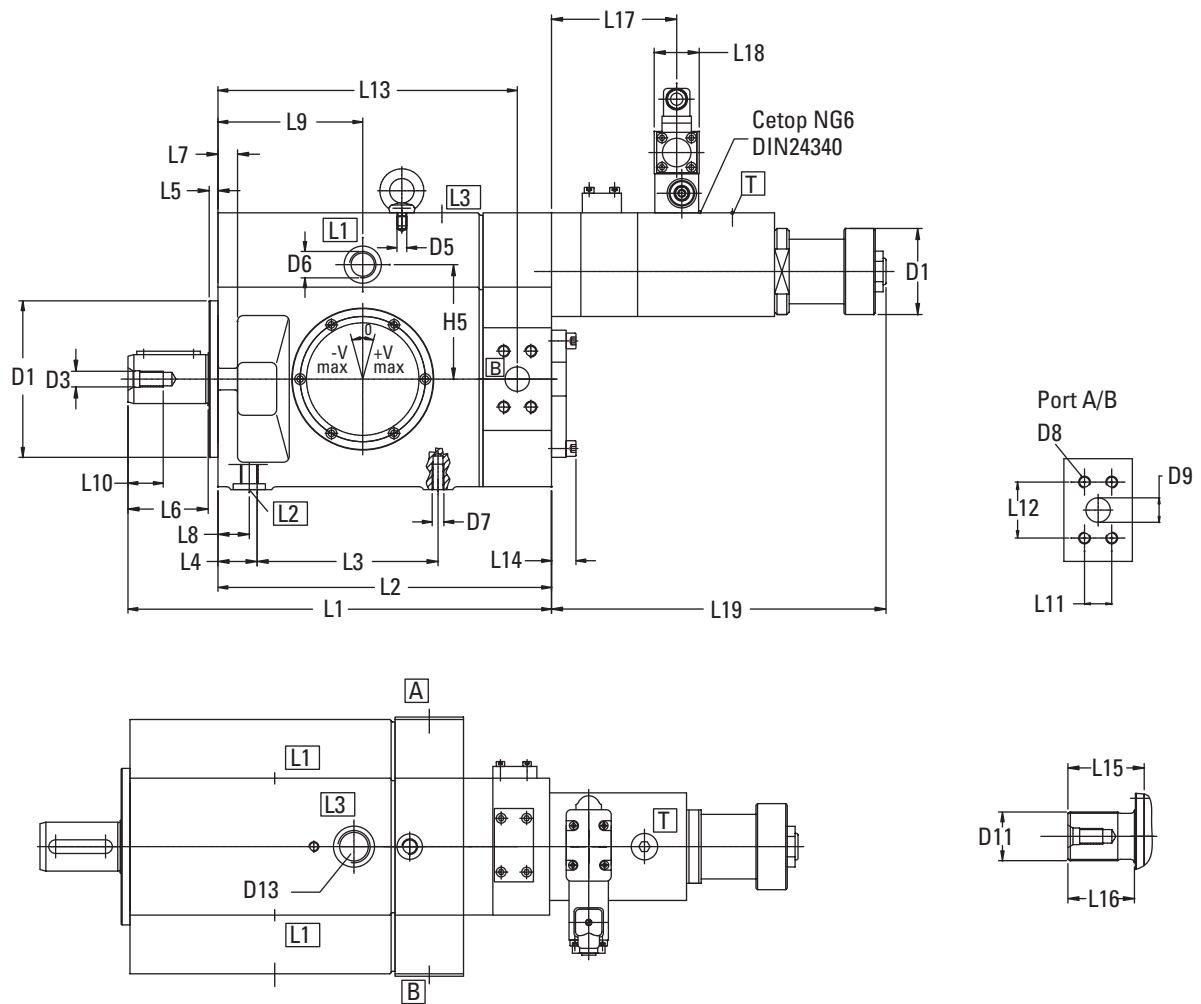

SIZE	H1	H2	H3	H4	H5	H6	H7	H8	H9	H10
066	227	162	90	41	93	130	53	88	137	127
090	227	162	90	41	93	130	53	88	137	127
130	283	207	113	53.5	117	130	64	110	170	127
180	283	207	113	53.5	117	130	64	110	170	127

SIZE	L1	L2	L3	L4	L5	L6	L7	L8	L9	L10	L11	L12	L13	L14	L15	L16	L17	L18	L19
066	342	274	150	35	8	58	16	26	120	28	27.8	57.2	245.6	25	68	58	104	46	267
090	342	274	150	35	8	58	16	26	120	28	27.8	57.2	245.6	25	68	58	104	46	267
130	433	341	185	40	9	82	20	32	148	36	27.8	57.2	306	26	78	68	128	46	342
180	433	341	185	40	9	82	20	32	148	36	31.8	66.7	306	26	78	68	128	46	342

# Dimensions - MVXS 066, 090, 130, 180

**Electro Hydraulic  
Displacement Control, SP**

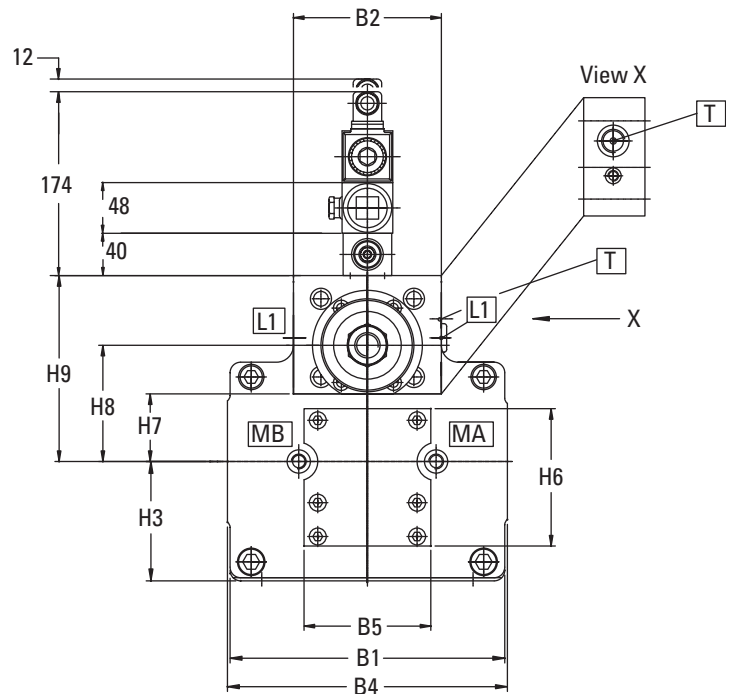

- [A] System pressure port (see detail)
- [B] System pressure port (see detail)
- [L1] Two drain ports, one supplied plugged.
- [L2] Supplementary drain or bleed plug. Must be drained in addition to [L1] if the pump is installed with the shaft input end pointing upwards.
- [L3] Oil filling or bleed plug. Must be drained in addition to [L1] if the pump is installed with the shaft input end pointing downwards.
- [MA] Gauge port system pressure G1/4"
- [MB] Gauge port system pressure G1/4"
- [MSt] Gauge port pilot pressure G1/4"
- [PSt2] Pilot pressure port G1/2"
- [T] Return line of control circuit G1/2"
- (...) Normally plugged

DIRECTION OF ROTATION	INLET PORT (HIGH PRESSURE SIDE)	OUTLET PORT (LOW PRESSURE SIDE)
Right Hand Rotation	B	A
Left Hand Rotation	A	B

SIZE	SAE-FLANGE 6000PSI
066	1"
090	1"
130	1"
180	1 1/4"

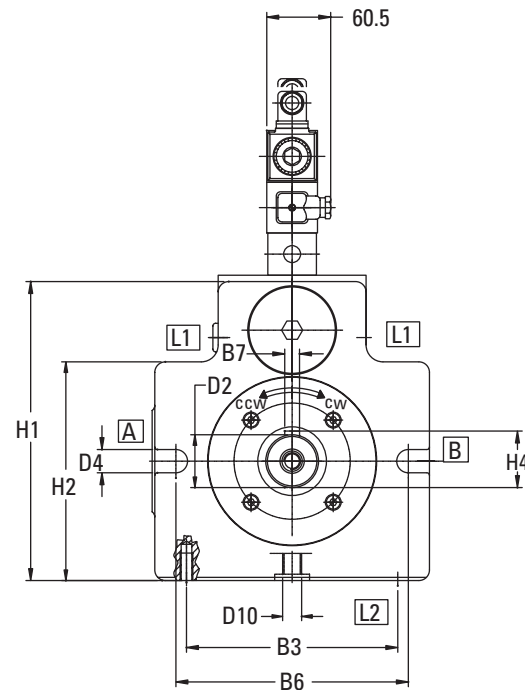

SIZE	B1	B2	B3	B4	B5	B6	B7 h9
066	210	116	160	235	120	180	10
090	210	116	160	235	120	180	10
130	260	140	200	265	120	224	14
180	260	140	200	265	120	224	14

SIZE	D1 h8	D2 k6	D3	D4	D5	D6 Light Execution	D7 DEEP	D8 DEEP	D9	D10 DEEP	D11	D12 SAEJ475
066	125	38	M12	18	M10	M22x1.5	M10 20	M12 18	25	M18x1.5 12	W40x1.25x10a	7/8-14 UNF
090	125	38	M12	18	M10	M22x1.5	M10 20	M12 20	25	M18x1.5 12	W40x1.25x10a	7/8-14 UNF
130	160	50	M16	22	M10	M26x1.5	M12 26	M12 20	25	M18x1.5 12	W50x1.25x10a	1 1/16-12 UNF
180	160	50	M16	22	M10	M26x1.5	M12 26	M14 22	30	M18x1.5 12	W50x1.25x10a	1 1/16-12 UNF

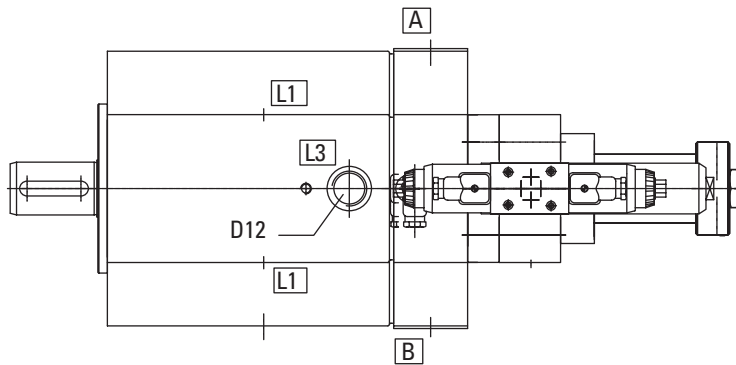
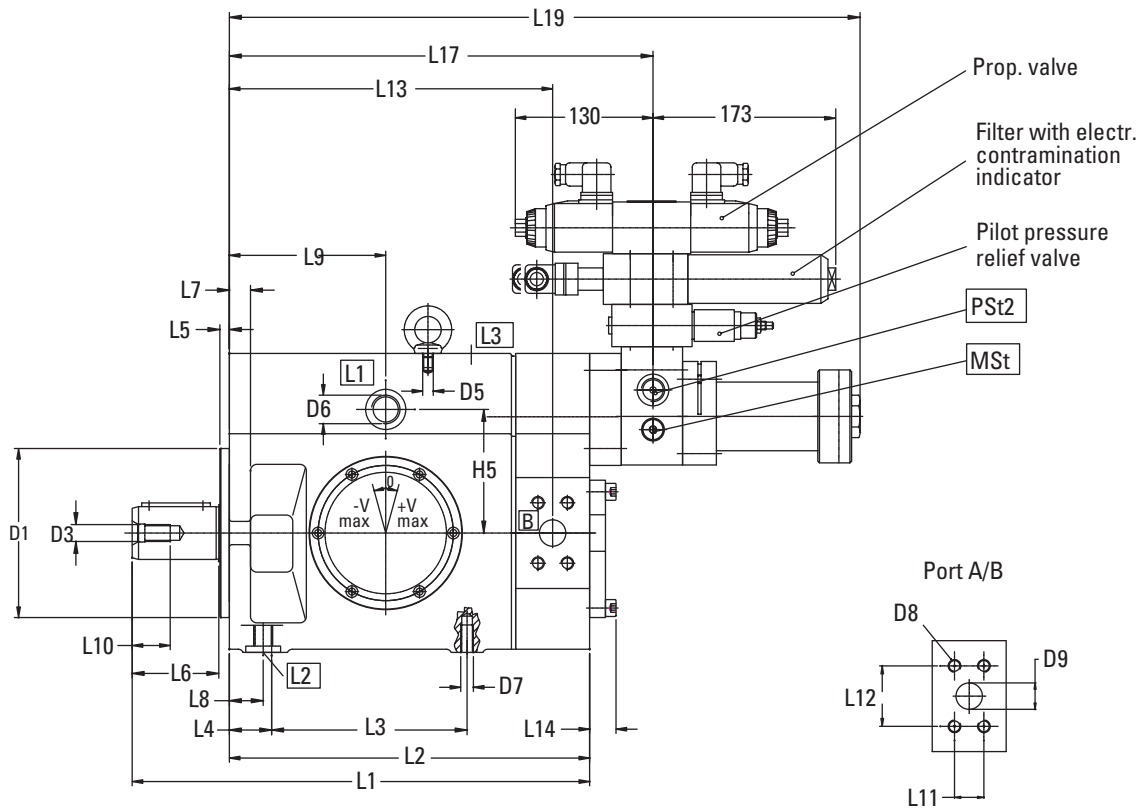

For Splined Data See Table

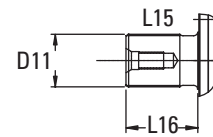

SIZE	H1	H2	H3	H4	H5	H6	H7	H8	H9
066	227	162	90	41	93	130	53	88	143
090	227	162	90	41	93	130	53	88	143
130	283	207	113	53.5	117	130	64	110	176
180	283	207	113	53.5	117	130	64	110	176

SIZE	L1	L2	L3	L4	L5	L6	L7	L8	L9	L10	L11	L12	L13	L14	L15	L16	L17	L18	L19
066	342	274	150	35	8	58	16	26	120	28	27.8	57.2	245.6	25	68	58	328	501	
090	342	274	150	35	8	58	16	26	120	28	27.8	57.2	245.6	25	68	58	328	501	
130	433	341	185	40	9	82	20	32	148	36	27.8	57.2	306	26	78	68	401	597	
180	433	341	185	40	9	82	20	32	148	36	31.8	66.7	306	26	78	68	401	597	

# Installation Data

## Installation position

### Shaft horizontal

Highest drain port is to be used. Drain line must be arranged in such a way that motor housing is kept full at all times. If necessary, the drain line is to be looped above the motor.

## Drain piping

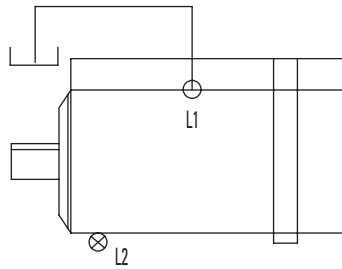

### Note:

Drain piping shown, with respect to installation positions, is required for proper bearing lubrication. Also, see case flushing information next page.

### Shaft down

Use venting port L3 (provided only on request). Pre-load drain port L1 with 0,2 bar (3 psi).

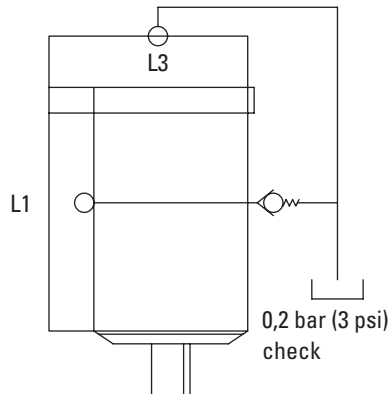

### Shaft up

Use venting port L2. Pre-load drain port L1 with 0,2 bar (3 psi).

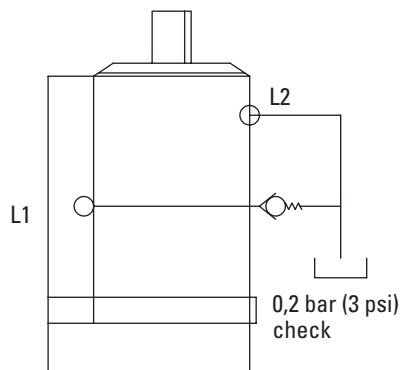



# Application Data - Fluid Recommendations

## Case flushing requirements

A check valve must not be used in the drain pipe. The drain pipe must interminate below the oil level in the reservoir.

For all other conditions with low pressure <20 bar (<300 psi) and low flow (<10% of Qmax) case flushing is required.

For operation with special fluids, HFB and HFC, case flushing is recommended.

## Flushing flow

Flushing flow via the motor case should be >1% of maximum flow. Maximum flushing flow depends on case pressure.

## Notes:

- All listed ratings are based on the use of a good quality fluid.
- Alternative fluids have a reduced tolerance for contamination over petroleum-based fluids. Good filtration is therefore critical.
- The motors will provide exceptional life when used with a good quality clean fluid at the motor's rating specified for that fluid.

## Fluids

Motors in the catalog are primarily designed to operate with conventional petroleum-based hydraulic oil. Alternative fluids and restrictions:

- Fluid maintenance is critical to the durability of all hydraulic components, and particularly so with hydraulic motors. This becomes even more of a factor when alternative fluids are used. All types of alternative fluids require extensive maintenance in order to maintain proper levels of water content, acidity, viscosity and contamination.

## Fluid Cleanliness

These motors are rated for anti-wear petroleum fluids with a contamination level of 18/15/13 per ISO 4406. Operation in fluids with higher contaminate levels is not recommended, and may

reduce the life of the motor's components. Fluids other than petroleum, severe service cycles, or extreme temperatures are cause for adjustment of these codes. Please contact your Eaton representative for special duty cycle recommendations.

Eaton motors, as well as any variable displacement piston motors, will operate with apparent satisfaction in fluids up to the rating specified here. Experience has shown, however, that motor and hydraulic systems lives are not optimized with high fluid contamination levels (high ISO cleanliness codes).

Proper fluid condition is essential for a long and satisfactory life of hydraulic components and systems. Hydraulic fluid must have the correct balance of cleanliness, materials, and additives for protection against wear of inclusion of air.

Essential information on the correct methods for treating hydraulic fluid is included in Eaton publication 561 - "Vickers Guide to Systemic Contamination Control" - available from your local Eaton distributor.

In this publication, filtration and cleanliness levels for extending the life of axial piston motors and other system components are listed. Included is an excellent discussion of the selection of products needed to control fluid condition.

## Ordering procedure

When ordering, please specify full model designation of items required; see "Model Codes" section of this catalog.

Note the following:

- Designation of variable displacement motors must include the supplementary designation of the required control type.

## FLUIDS

TYPE	CLASSIFICATION	MAX. PRESSURE BAR	MAX. SPEED RPM	RECOMMENDED SEAL MATERIAL	MAX OPERATING TEMPERATURE °C	BEARING LIFE
Oil in Water Emulsion	HFAE	Not Rated				0
Water in Oil Emulsion	HFB	250	1800	Fluorocarbon	49	50%
Water Glycol	HFC	250	1800	Fluorocarbon	49	25%
Phosphate Ester	HFDR	350/420	1800	Fluorocarbon	66	100%
Polyol Ester	HFDU	350/420	1800	Fluorocarbon	66	100%

**Eaton**  
14615 Lone Oak Road  
Eden Prairie, MN 55344  
USA  
Tel: 952 937-9800  
Fax: 952 974-7722  
[www.hydraulics.eaton.com](http://www.hydraulics.eaton.com)

**Eaton**  
20 Rosamond Road  
Footscray  
Victoria 3011  
Australia  
Tel: (61) 3 9319 8222  
Fax: (61) 3 9318 5714

**Eaton**  
Dr.-Reckeweg-Str. 1  
D-76532 Baden-Baden  
Germany  
Tel: +49 (07221) 682-0  
Fax: +49 (07221) 682-788

**VICKERS**<sup>®</sup>

**EATON**

**Vickers**

© 2003 Eaton Corporation  
All rights reserved  
Printed in USA  
Document No. V-MOPI-MC001-E  
March 2003