

# Piston Pumps & Motors

---



## 5 USgpm Fixed Inline Piston Units

PFB5-(F)R(Y)-21

PFB5-(F)L(Y)-21

(M) \*FB5-(F)U(Y)-11/20

PMFB5-(F)U-10

● INCLUDED IN VALVE PLATE S/A

■ INCLUDED IN ROTATING GROUP KIT

MODEL	● VALVE PLATE S/A	PIN (2 REQ'D)	GASKET
PMFB5-U-10	—	12987	▲ 231643
*FB5-(F)U(Y)-11	938551	167237	▲ 279614
*FB*-(F)U(Y)-20			
PFB5-(F)R(Y)-21	942313		
PFB5-(F)L-(Y)-21	942314		

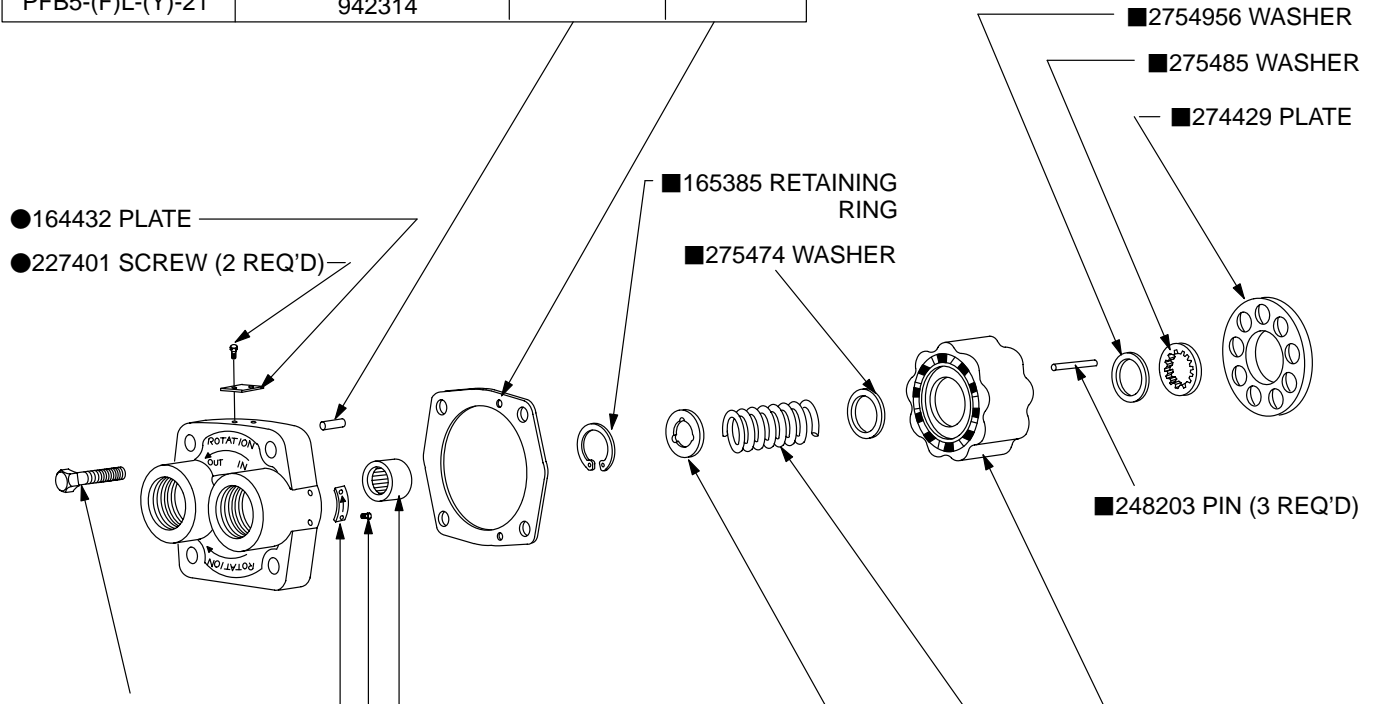

1253 SCREW (4 REQ'D)  
TORQUE TO 150-180 LB. IN.

MODEL	LIFT LIMITER	SPRING	CYLINDER BLOCK	ROTATING GROUP KIT
	— THESE PARTS ARE INCLUDED IN ROTATING GROUP KIT			
PMFB5-U-10	—	274787	274670	938260
PFB5-(F)U(Y)-11/20/21	273409		316000	938262
(M)-MFB5-(F)U(Y)-11/20			290059	938265
M-MFB6-**-20		272015		922994

MODEL	HOUSING
PMFB5-U-10	231559
*FB5-(F)U(Y)-11	274668
*FB*-(F)U(Y)-20	323951
PFB5-(F)R(Y)-21	
PFB5-(F)L-(Y)-21	

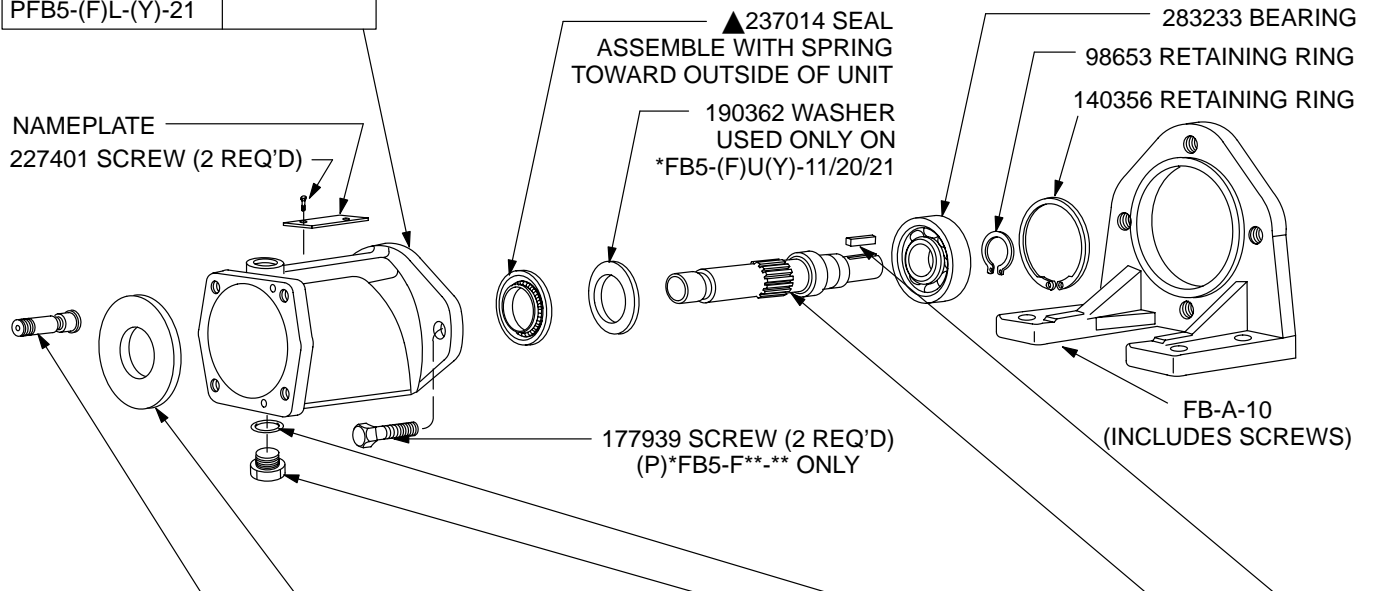
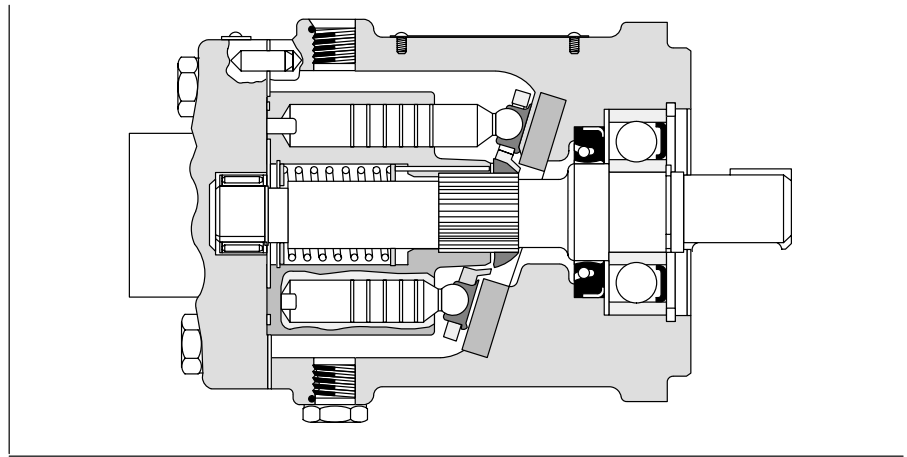

MODEL	PLUG	"O" RING
*FB5-(F)U(Y)-10/11	189087	▲154126
*FB*-(F)U(Y)-2*	181728	▲154128
PFB5-*R/L*-211		

MODEL	SHAFT	KEY
*FB5-U-11/2*	274669	157671
*FB5-UY-11/20	266161	142843
PFB5-*R/L*-21		
PMFB5-U-10	#274669	157671
M-MFB6-*G-20	295237	—

MODEL	PISTON S/A KIT	SWASH PLATE	ROTATING GROUP KIT
PMFB5-U-10	942229	319245	938260
PFB5-(F)U(Y)-11/20/21			938262
(M)-MFB5-(F)U(Y)-11/20			938265
M-MFB6-*G-20	942350	344049	922994

THESE PARTS ARE INCLUDED IN ROTATING GROUP KIT

▲ INCLUDED IN 919239 SEAL KIT

F3 EQUIVALENT SEAL KIT 919311

#WHEN ORDERING THIS SHAFT, ALSO ORDER 273409 LIFT LIMITER.

# Model Code

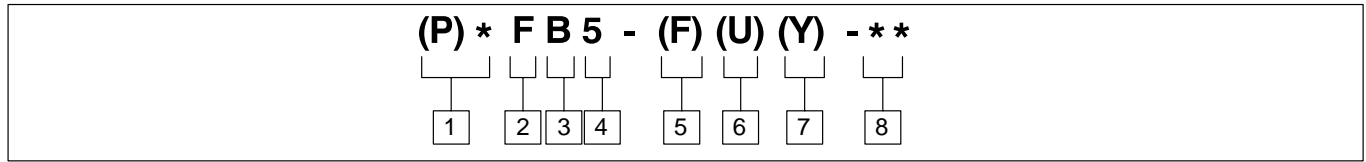

**1 Model**  
**M\*** - Mobile Unit  
**P** - Pump  
**M** - Motor  
**PM** - Pump or Motor

**2 Fixed Displacement**

**3 Inline Type**

**4 USgpm flow rating @ 1800 rpm**  
**5** - 5 USgpm

**5 Mounting**  
 Omitted - Flange  
**F** - Foot bracket

**6 Rotation**  
 (Viewed from shaft end)  
  
**U** - Either direction  
**R** - Right hand (CW)  
**L** - Left hand (CCW)

**7 Shaft**  
 Omitted - Light duty  
**Y** - Heavy duty

**8 Pump Design**  
**10**  
**11**  
**20**  
**21**

For satisfactory service life of these components, use full flow filtration to provide fluid which meets ISO cleanliness code 16/13 or cleaner. Selections from pressure, return, and in-line filter series are recommended.