

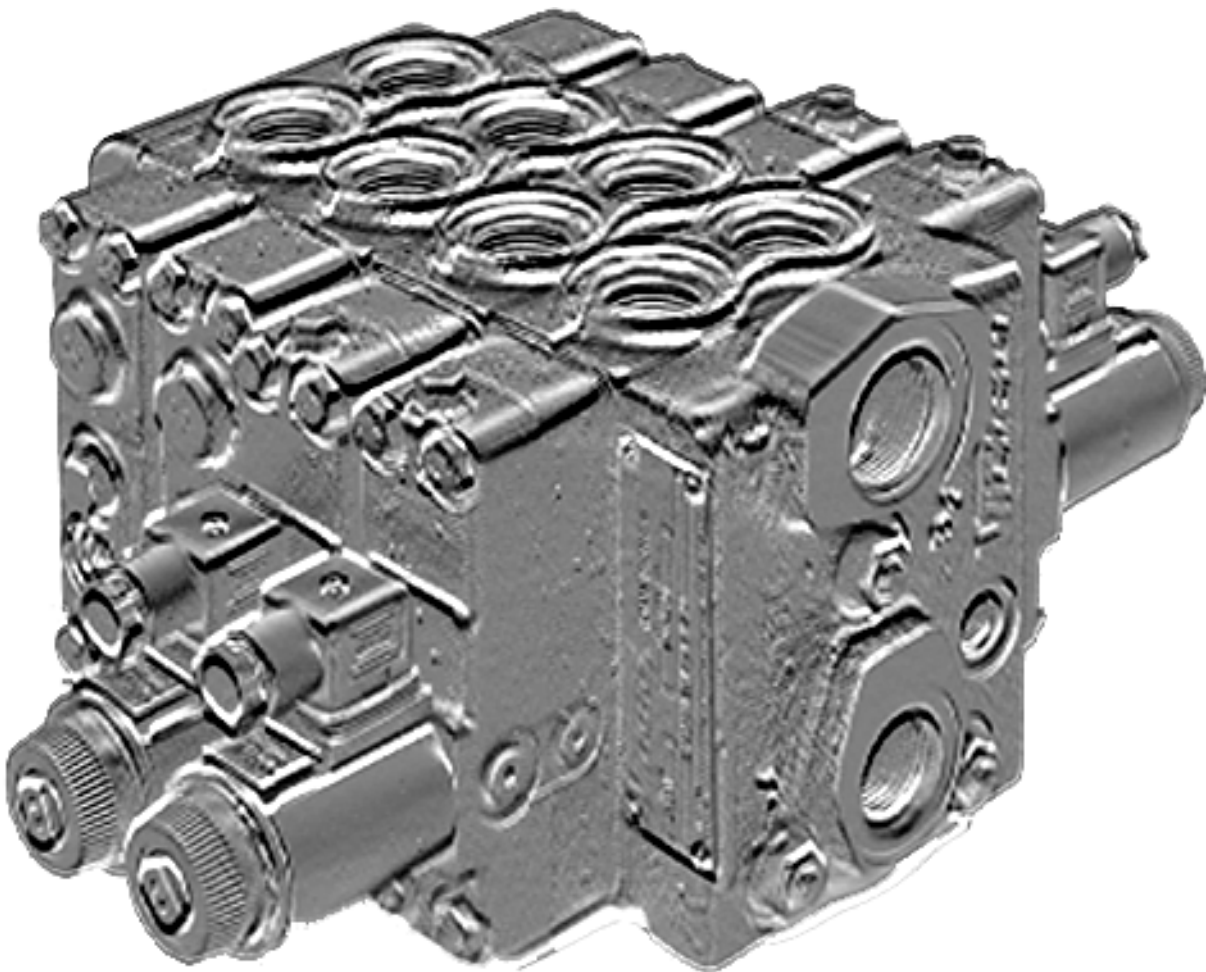

CMX Sectional Directional Valve -25 Design

CMX100 & CMX160 Hydraulic & Electrohydraulic Actuation



Contents

| | |
|--|----|
| Section 1 – Introduction | 4 |
| Purpose of Manual | 4 |
| General Information | 4 |
| Ratings | 4 |
| Port & Mounting Hole Sizes | 5 |
| Valve Section Dimensions & Weights | 6 |
| Section 2 – Description | 6 |
| General | 6 |
| Mounting | 7 |
| Control Types | 7 |
| Inlet Bodies | 12 |
| CMX160/100 Mid-Inlet | 13 |
| End Cove | 15 |
| Section 3 – Principles of Operation | 16 |
| General | 16 |
| Operation of Valve Elements | 16 |
| Section 4 – Installation & Operating Instructions | 17 |
| Hydraulic Tubing | 17 |
| Hydraulic Fluid Recommendations | 17 |
| Section 5 – Service & Maintenance | 17 |
| Inspection | 17 |
| Adding Fluid to the System | 17 |
| Replacement Parts | 17 |
| Section 6 – Valve Bank Disassembly | 18 |
| General Information | 18 |
| Disassembly of End Covers | 18 |
| Control Cap & Internal Parts Removal | 18 |
| Inspection, Repair, and Replacement | 19 |
| Assembly | 19 |
| Troubleshooting | 20 |
| On-vehicle Test | 21 |
| Adjusting Factory-preset Fixed Meter-out Port Relief Valve Pressure Setting | 21 |
| Adjusting Factory-preset Adjustable Meter-out Port Relief Valve Pressure Setting | 22 |
| Model Codes | 23 |
| Exploded Views | 26 |
| Fluid Cleanliness | 30 |

Section 1 - Introduction

A. Purpose of Manual

This manual has been prepared to assist users of Vickers CMX series high pressure load sensing directional valves in properly maintaining and repairing their units. In the sections that follow, various features are discussed along with the proper maintenance and overhaul of these units.

Supporting literature for this overhaul manual are:

- Vickers literature 536 - Application Guide
- Vickers literature 592 - CMX Start-Up & Troubleshooting Guide

B. General Information

CMX sectional valves are generally assembled in a bank of CMX100 sections or CMX160 sections consisting of an inlet section, from 1 to 8 valve sections, and an end cover. When used with a mid-inlet section, it is possible to assemble a valve bank with up to eight CMX100 valve sections on the one side and up to eight CMX160 valve section on the other side.

C. Ratings

With the -25 design comes the ability to combine both electrohydraulic and hydraulic actuation in the same valve bank as a standard feature.

Each valve bank is identified by a model code stamped on its inlet/mid-inlet section. Identification of individual valve sections is by means of an assembly number stamped on the valve section body. Model codes can have a number of optional variations within a basic model series. These options are determined by specific vehicle/machine performance requirements and are covered by variables in the model code. For information on valve section, valve bank and valve bank with mid-inlet model codes, see pages 23 – 25.

Service inquires should always include the complete valve bank model code and assembly number as stamped on the inlet/mid-inlet section. Service inquires for *specific* valve sections should always include the valve section assembly number which is stamped on the opposite side of the valve from the cylinder ports.

| Model Series | Rated Flow * l/min (USgpm) | Hydraulic Horsepower | Rated Pressure bar (psi) Pressure Port | Rated Pressure bar (psi) Actuator Port | Rated Pressure bar (psi) Pilot, Tank & Drain Ports |
|--------------|-------------------------------|-------------------------|--|--|---|
| CMX100–F/G/W | 100 (26) | 77 | 350 (5075) | 380 (5510) | 35 (508) |
| CMX100–S | 100 (26) | 55 | 250 (3625) | 290 (4200) | 35 (508) |
| CMX160–F/G/W | 160 (42) | 124 | 350 (5075) | 380 (5510) | 35 (508) |
| CMX160–S | 160 (42) | 89 | 250 (3625) | 290 (4200) | 35 (508) |

* At 14 bar (200 psi) load-sensing pressure drop.

D. Port & Mounting Hole Sizes mm (inch) 2.

| Model Series | Actuator Ports | Pressure Port (Inlet Cover) | Tank Port (Inlet Cover) | Pilot, Load Sensing, Deceleration, External Drain & Cooling Ports | Valve Mounting Holes (3 Places)◆ | | Auxiliary "P" Port | Auxiliary "T" or Gage Port |
|--------------|-----------------------|-----------------------------|-------------------------|---|----------------------------------|--------------------------------|---------------------|----------------------------|
| | | | | | Metric | Inch | | |
| CMX100-F | 12,7 (.50) diameter†† | (1.0625-12)** | (1.3125-12)** | (.5625-18)** | M10×1,5-6H 20,0 deep | .4375-14 UNC-2B .75 deep | (.5625-18)** | (.5625-18)** |
| CMX100-G | 12,7 (.50) dia.† | (1.0625-12)** | (1.3125-12)** | (.5625-18)** | M10×1,5-6H 20,0 deep | .4375-14 UNC-2B .75 deep | (.5625-18)** | (.5625-18)** |
| CMX100-S/W | (1.0625-12)** | (1.0625-12)** | (1.3125-12)** | (.5625-18)** | M10×1,5-6H 20,0 deep | .4375-14 UNC-2B .75 deep | (.5625-18)** | (.5625-18)** |
| CMX160-F | 19 (.75) dia.†† | 19 (.75) dia.†† | 31,8 (1.25) diameter† | (.5625-18)** | M12×1,75-6H 18,0 deep | .5000-13 UNC-2B .71 deep | 19 (.75) diameter†† | (.5625-18)** |
| CMX160-G | 19 (.75) dia.† | 25 (1.00) dia.† | 31,8 (1.25) diameter† | (.5625-18)** | M12×1,75-6H 18,0 deep | .5000-13 UNC-2B .71 deep | 25 (1.00) diameter† | (.5625-18)** |
| CMX160-S/W | (1.3125-12)** | 25 (1.00) dia.† | 31,8 (1.25) diameter† | (.5625-18)** | M12×1,75-6H 18,0 deep | .5000-13 UNC-2B .71 deep | 25 (1.00) diameter† | (.5625-18)** |

** SAE straight-thread O-ring connection.

† SAE 4-bolt flange, standard pressure series (code 61).

†† SAE 4-bolt flange, high pressure series (code 62).

◆ Valve banks with end inlet have three mounting holes: two in inlet body and one in end cover. Valve banks with mid-inlet have four mounting holes: two CMX160-size holes in mid-inlet body, one CMX160-size hole in one end cover and one CMX100-size hole in the other end cover.

E. Valve Section Dimensions & Weights

CMX100-S2-*-** 290 bar (4200 psi) rating

Hydraulic Actuation -

Dimensions: 201 mm (7.9 in) long x 47,0 mm (1.85 in) wide x 149 mm (5.87 in) high.

Weight: @ 7,3 kg (16.2 lbs)

Electrical Actuation -

Dimensions: 366 mm (14,4 in) long x 47,0 mm (1.85 in) wide x 149 mm (5.87 in) high.

Weight: @ 9,0 kg (19.8 lbs)

CMX100-F2-*-** 380 bar (5510 psi) rating

Hydraulic Actuation -

Dimensions: 201 mm (7.9 in) long x 59,0 mm (2.32 in) wide x 144 mm (5.67 in) high.

Weight: @ 8,7 kg (19.2 lbs)

Electrical Actuation -

Dimensions: 366 mm (14.4 in) long x 59,0 mm (2.32 in) wide x 144 mm (5.67 in) high.

Weight: @ 10,4 kg (22.8 lbs)

CMX160-S2-*-** 290 bar (4200 psi) rating

Hydraulic Actuation -

Dimensions: 243 mm (9.6 in) long x 51,0 mm (2.01 in) wide x 172 mm (6.77 in) high.

Weight: @ 10,2 kg (22.5 lbs)

Electrical Actuation -

Dimensions: 386 mm (15.2 in) long x 51,0 mm (2.01 in) wide x 172 mm (6.77 in) high.

Weight: @ 11,8 kg (26.1 lbs)

CMX160-F2-*-** 380 bar (5510 psi) rating

Hydraulic Actuation -

Dimensions: 243 mm (9.6 in) long x 75,0 mm (2.95 in) wide x 165 mm (6.50 in) high.

Weight: @ 13,4 kg (29.6 lbs)

Electrical Actuation -

Dimensions: 386 mm (15.2 in) long x 75,0 mm (2.95 in) wide x 165 mm (6.50 in) high.

Weight: @ 15,1 kg (33.2 lbs)

Note: Dimensions and weights for "G" and "W" sections are identical to "F" sections.

Section 2 - Description

A. General

Vickers CMX Series of sectional valves, coupled with PVH series variable displacement open-loop pumps, comprise the heart of Vickers load-sensing POWER MATCH™ hydraulic systems. As the name implies, the system delivers pump output power matching a specific load requirement. In contrast, the output flow and/or pressure of a non-load sensing system could exceed that required by the load, subsequently wasting fuel and dissipating excess power as heat.

Essentially, each operating section consists of: two meter-out elements, one meter-in element, two load-drop checks, two pilot-operated relief valves and two load-sensing check valves. Refer to Figures 4 and 6 for a sectional view. CMX sectional valves do not incorporate a separate anti-cavitation check for each port. The meter-out elements are used for cavitation protection. A bolt-on anti-cavitation check valve module is available for applications requiring superior pressure drop characteristics.

The pilot-operated four-way directional control valve obtains its pilot pressure through a hydraulic remote control (HRC) valve or internally through an integral electrohydraulic pilot valve. CMX valves are available in two flow sizes: CMX100 for rated flows of 100 l/min (26 USgpm), and CMX160 for 160 l/min (42 USgpm). Flange-ported models have rated pressure of 350 bar (5075 psi). Straight threaded port models are rated at 290 bar (4200 psi). Up to eight sections can be stacked into an individual valve bank (mid-inlet assemblies can have 16 sections). Refer to Figure 1.

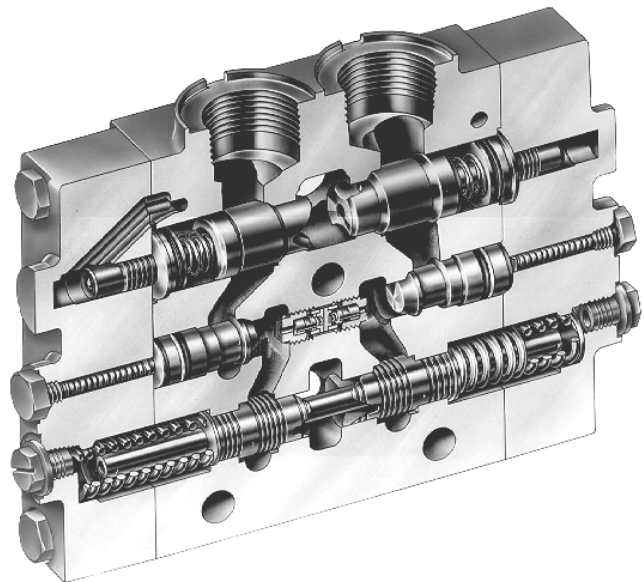

Figure 1. CMX Hydraulic Actuator Cutaway

A full-flow high-pressure line connects the system pump's outlet to valve inlet P. Flow from tank port T is returned to the tank via a low-pressure line. For hydraulically actuated valves, the pilot pressure lines connect ports C1 and C2 in each valve section to the hydraulic remote control valve, which commands the CMX. A small line connected to load-sensing port LS feeds the highest of the load pressures (actuator port A or B) sensed in the valve back to the pump's control. The pump control senses the difference between the load and pump outlet pressures and varies the pump displacement to keep the difference at a constant load sense differential pressure, typically 20 bar (290 psi). This differential pressure is applied across the valve's meter-in spool, resulting in pump flow being determined by the degree of spool opening, independent of load pressure.

Meter-in pressure compensation provides nearly constant flow, independent of valve pressure drop, for better load control and increased productivity. This enables an operator to simultaneously control multiple work functions with minimal interference from one function on another.

Multiple banks of valves are applied by connecting their inlets to the pump outlet. Tank lines can also connect together to simplify routing of return flow and to help reduce cavitation. Load-sensing lines connect to feed the highest load signal to the pump. In some applications, optional ports are provided that allow connecting the load sensing line between valve banks.

CMX valves with integral electrohydraulic pilots provide an internal pressure output signal (pilot pressure) proportional to an input current. The pilot pressure controls the meter-in and meter-out elements which precisely control resistive and overhauling loads respectively.

B. Mounting 5.

Physically compact in design for ease of mounting, the valves incorporate a three point mounting to ensure a rigid installation. Because of their pilot actuation, the valves allow generous flexibility for location and installation in a vehicle.

C. Control Types 6.

Meter-in Pressure Compensation

Competitive designs typically incorporate a separate pressure compensator for each spool to provide individual function pressure compensation. The Vickers CMX incorporates a unique design which provides meter-in pressure compensation by taking special advantage of the natural flow forces. This feature completely eliminates the need for a separate pressure compensator for each function. The result is fewer moving parts . . . i.e., improved stability and reliability.

Meter-in Spool Options

The CMX control valve offers a choice of either flow (velocity) control (referred to as load sensing up to this time) or pressure (force/torque) control meter-in functions.

It should be noted that all of these control options are available in either hydraulic or electrohydraulic configurations.

In order to fully describe the function characteristics desired, it is necessary to specify both the meter-in spool and the related meter-out element.

Meter-in Element (Refer to Figure 2)

The meter-in spool is shown in the center (neutral) position. Command pressure is applied to either C1 or C2 and directs flow to the desired actuator port. During this explanation, assume command pressure is applied to C1. When command pressure reaches a level that overrides meter-in spring force, the meter-in spool moves to the right. Movement of the spool will close the chamber drain opening through the spool and open pressure to the load drop check and load sense check valve. The load sense check poppet then shifts to the left, allowing pressure to the load sensing feedback port (LS). Pump outlet pressure (P) will be approximately 20 bar (290 psi) higher than the load sensing feedback pressure at (LS). By varying pilot command pressure at C1, the meter-in spool will modulate flow to the cylinder "B" port and precise metering of flow to the load can be obtained.

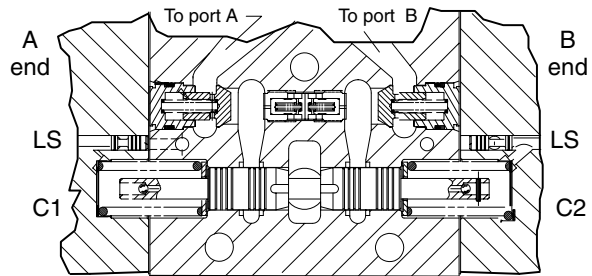

Figure 2. Meter-in element in neutral.

In a load sensing system, if command pressure at C1 is reduced, spring force will center the meter-in spool and the load sensing pressure will decay through the load sense decompression orifice. This allows pump outlet pressure to reduce to standby pressure.

Meter-out Element (Refer to Fig. 3.)

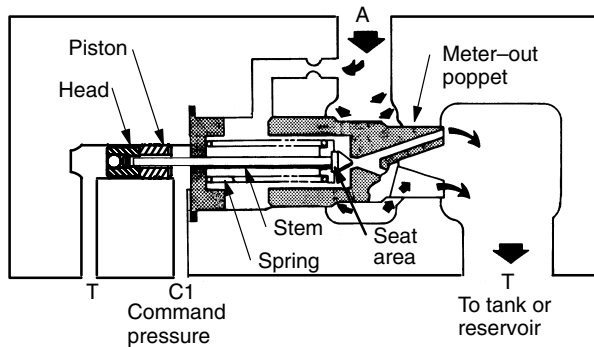

Figure 3. Meter-out element

There are two meter-out elements, one for each cylinder port. Essentially, the CMX meter-out element is a variable orifice between one of the actuating ports and the reservoir. The meter-out element is used to restrict exhaust flow from an actuator (motor or cylinder). As flow is restricted, the speed of the actuator slows down. The meter-out element is positioned by a simple bleed servo which is controlled by command pilot pressure at C1. Command pilot pressure causes the piston to move and the stem, being connected to the piston, automatically follows. This opens the left side of the meter-out poppet to the reservoir. Pressure then lowers in the spring chamber, and actuator port pressure causes the poppet to shift to the left, allowing more oil into the reservoir. When command pilot pressure decreases at C1, the piston and stem move under the influence of the spring in the opposite direction. This causes the meter-out poppet to start restricting flow; consequently, less oil is ported into the reservoir. When the meter-out poppet bottoms against its seat in the body, exhaust oil flow ceases to the reservoir, and actuator movement stops.

Meter-out Poppet Variations

Several different meter-out poppets are available which provide different area gains. A high gain poppet (low ΔP at rated flow) provides better control when lowering a light load. A low gain poppet (high ΔP at rated flow) provides better control when lowering heavy loads.

Meter-out poppets are rated according to the actuator port to tank pressure drop, in bar, across the poppet at the valve's rated flow with the poppet fully opened.

Relief Valve Element

When actuator port pressure overcomes relief valve spring force, the poppet moves off the seat. Actuator port pressure is

then released to the meter-out piston area and causes the piston to shift. Since the servo stem is connected to the piston, the stem also shifts to the left and opens actuator flow to the reservoir. As flow to the reservoir is obtained, actuator port pressure is relieved. Refer to Figure 3.

Meter-out Spool

A version of the CMX that replaces the meter-out poppets with a spool is available. This version does not provide meter-out metering, load holding or relief valve protection. This version can be used with counterbalance and load lock valve circuits. Two meter-out spool versions are available; one is open in neutral, the other provides restricted flow to tank in neutral. The restriction is equivalent to a 0,75 mm (.030 in.) orifice.

Hydraulic Actuation

Pilot pressure is supplied to each section via two #6 SAE O-ring boss ports (.563-18 UNF-2B straight thread) located on each control cap. Pilot drain connections can be made internally to the tank port or externally to the reservoir. External drain is always the preferred configuration and **MUST** be used if tank pressure is high due to the installation of a back pressure check valve, or if high pressure transient "spikes" are likely.

It is important to note that the meter-out servo is referenced to the valve bank drain, while the meter-in spool is referenced to the opposite port command pressure. This requires the HRC drain pressures to be considered, since different drain pressures for the valve bank and the HRC will alter meter-in and meter-out phasing. Ideally, both the HRC and the CMX valve bank should be drained directly to reservoir via generous lines.

Hydraulic actuation data:

| Pilot Pressure | M/O bar (psi) | M/I "06" Spring bar (psi) | M/I "12" Spring bar (psi) |
|----------------|---------------|---------------------------|---------------------------|
| At cracking | 4,2 (61) | 6,2 (90) | 11,4 (165) |
| At rated flow | 13,8 (200) | 15,5 (225) | 20,7 (300) |

Tolerance: ± 1 bar (15 psi)

Required shift volume (displacement):

| Metering | CMX100 | CMX160 |
|------------------------------|---------|---------|
| M/I (neutral to full stroke) | 1,63 cc | 2,56 cc |
| M/O | 1,01 cc | 2,56 cc |

For additional information see Vickers CMX Application Guide - literature number 536.

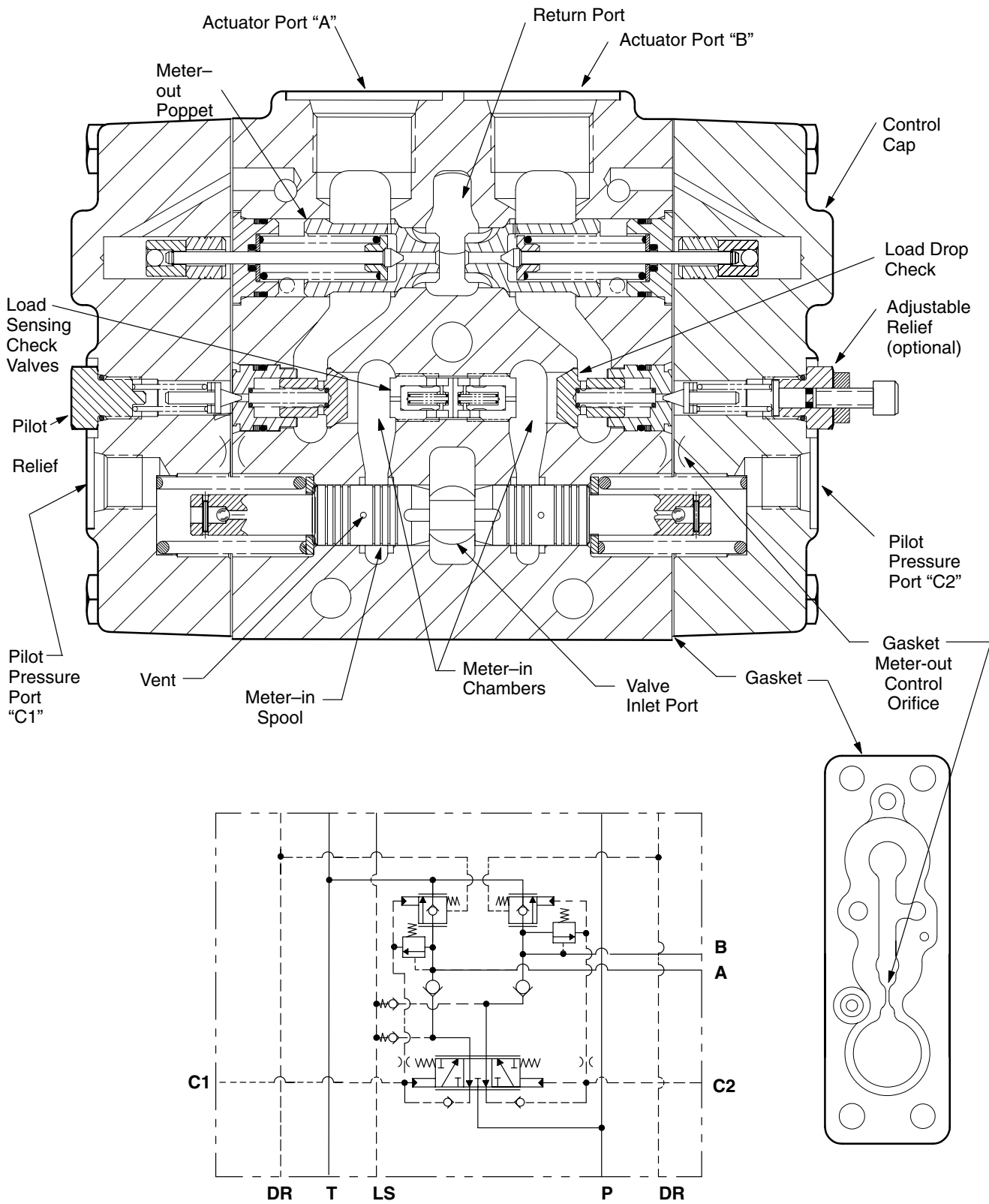

Figure 4. CMX Hydraulic Sectional View & Schematic 7.

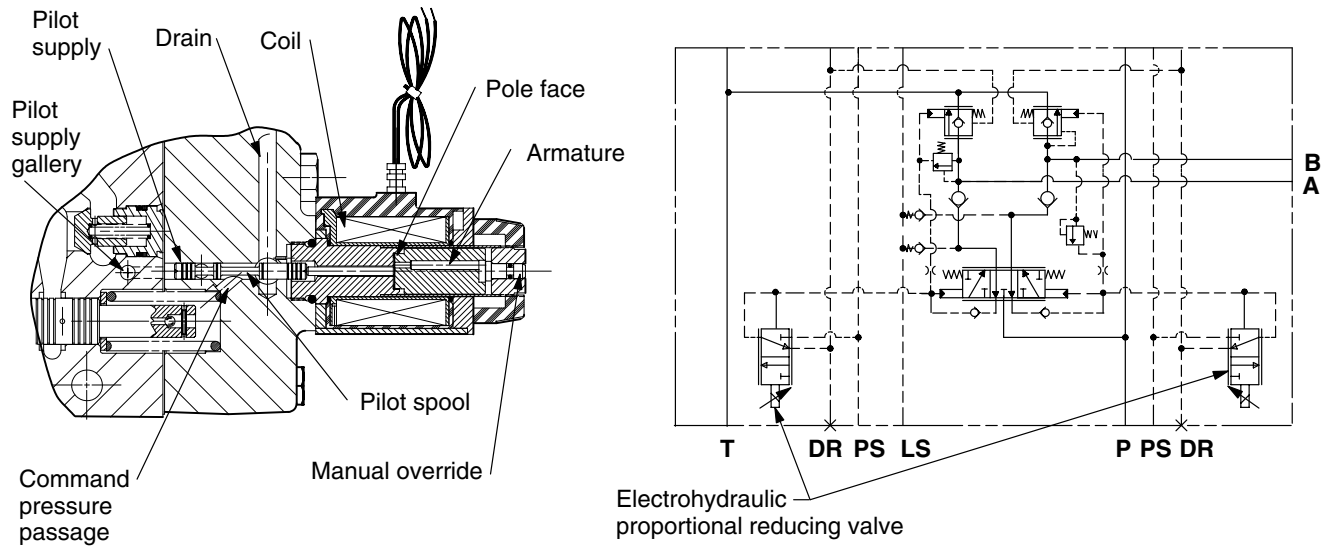

Figure 5

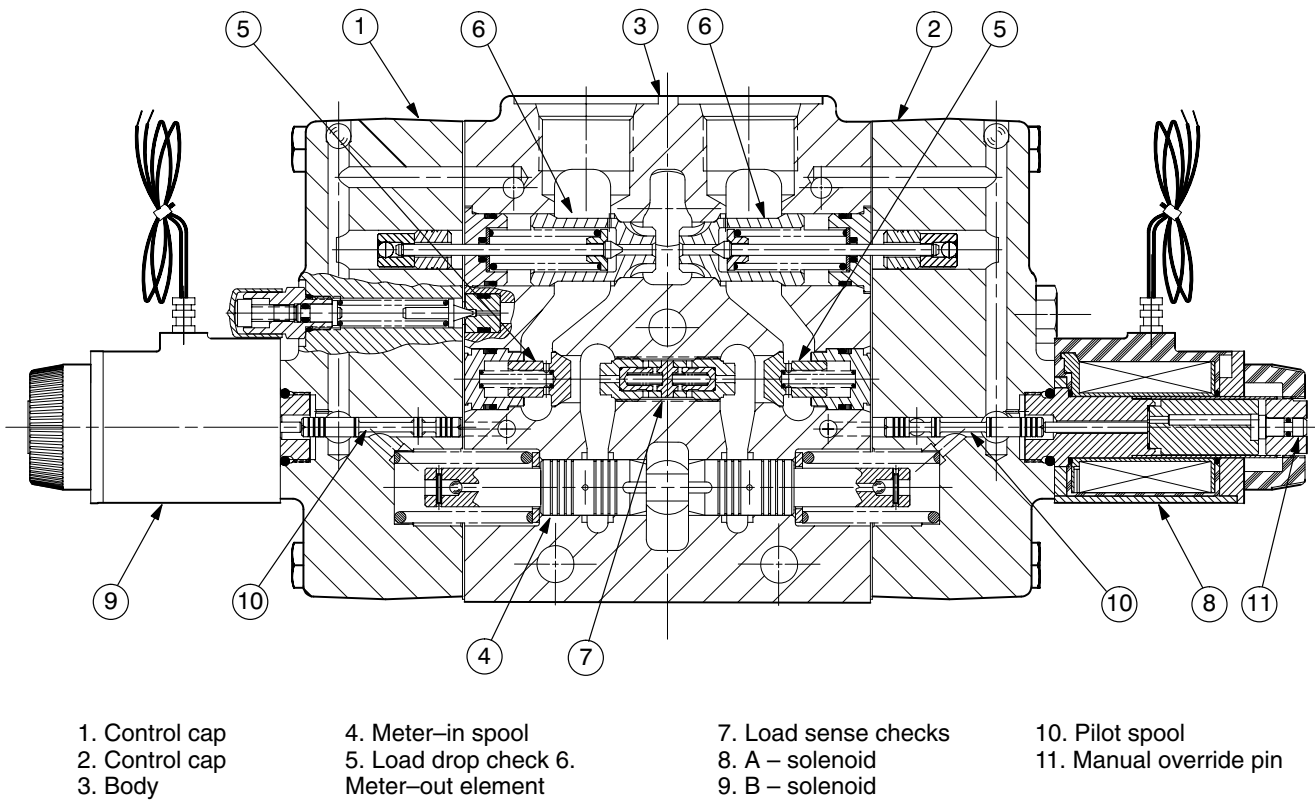

Figure 6. Sectional view showing a basic electrohydraulic valve section. 8.

Electrohydraulic Actuation

Electrohydraulic CMX sectional valves operate on the same principles as the hydraulic valves, with the addition of an electrohydraulic proportional reducing valve (Figure 6) to convert an electrical input signal to a proportional command pressure signal that operates the valve. The solenoid provides an output force proportional to the input current that acts on the solenoid end of the pilot spool.

When the solenoid is energized, the pilot spool is moved away from the solenoid, closing the command port to tank and opening the pilot supply to the command port. Command port pressure is supplied to the feedback end of the pilot spool through the passage in the control cap gasket. When the feedback pressure begins to balance the solenoid force, the pilot spool closes the pilot supply passage. As the command pressure rises, the feedback pressure overcomes the solenoid, and the pilot spool moves to open the control port to tank. The pilot spool modulates to balance the feedback pressure against the solenoid output force, thus providing an output pressure proportional to the solenoid input current. The pilot spool and bore are designed for zero overlap, so deadband is minimized.

The pressure output serves as the command pressure to actuate the CMX meter-in and meter-out elements. The signal to the solenoid should be conditioned to a pulse width modulated voltage or current signal. DC power, up to the coil rating, may also be used for “on-off” operation.

| | |
|--|---------------|
| Supply Voltages: | 12/24 VDC |
| Maximum Current: | 1.4/.7 AMP |
| Coil Resistance: | 6.4/25.5 ohms |
| Recommended PWM Freq./Dither Freq.: | 100 Hz |

Solenoids are available with DIN standard 43650 plugs, Metri-Pack[®] connector, or flying leads.

Valves are available with either internal or external pilot supply. On models with the internal pilot option, pilot pressure is supplied to the proportional reducing valve by an internal passage that is connected to the system supply passage in the inlet body. These models require that the minimum system pressure be maintained to the specified limits to assure proper valve actuation.

Electrohydraulic CMX valves may be operated manually in the event of electrical control failure by depressing the manual override pin (see #11, Figure 6), located on the end of each solenoid, with a screwdriver or similar tool.

Internal Pilot Supply

Minimum **system** pressure:

Valves with Type “06” meter-in spring – 19 bar (275 psi)

Valves with Type “12” meter-in spring – 24 bar (350 psi)

External Pilot Supply

Minimum pressure:

Valves with Type “06” meter-in spring – 19 bar (275 psi)

Valves with Type “12” meter-in spring – 24 bar (350 psi)

Since both electrohydraulic reducing valves are referenced to a common drain via the end cover, drain pressure is not critical. Internal drain-to-tank and external drain options are available.

Cutaway views of the hydraulic and electrohydraulic versions of the CMX are shown in Figures 4 and 6, along with schematic diagrams. The relief valve pilot stages are shown in detail in the schematic diagrams used in this discussion to promote a better understanding of the valve’s operation.

NOTE

1. If high pressure transients are present in the tank line, then external drain should be used to avoid function interaction. If the tank pressure is above 8,6 bar (125 psi), then external drain should be used to avoid exceeding the 35 bar (500 psi) pressure rating for the pilot passages.
2. Under certain operating conditions (high inlet pressure, fully shifted, and open relief valve), pilot drain flow can be as high as 4 L/min (1 USgpm) for each active section. Total anticipated drain flow must be considered when sizing drain lines.

D. Inlet Bodies

Standard End Inlet Body

The standard inlet body (Figure 7) provides connections for pump, tank, and load sense. On electrohydraulic valve banks, a connection is also provided for pilot supply, which may be internal or external. For internal pilot supply, an internal passage connects the pilot supply to the pressure port. For external pilot supply, this connecting passage is blocked by a $\frac{1}{4}$ -28 UNF set screw (.125 in. hex key) accessible through the pump port, and the "XP" external connection is made through a #6 SAE O-ring boss port (.563-18 UNF-2B thread).

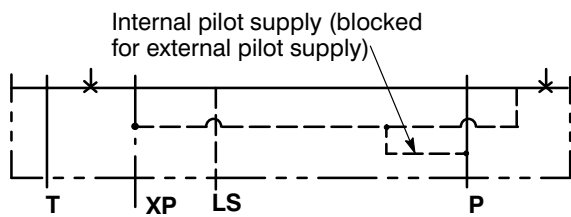

Standard end inlet schematic

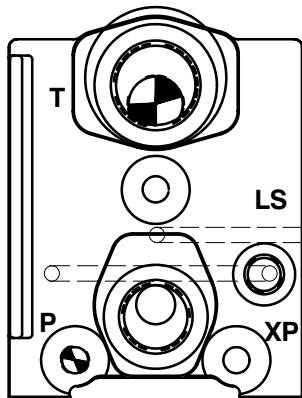

CMX100

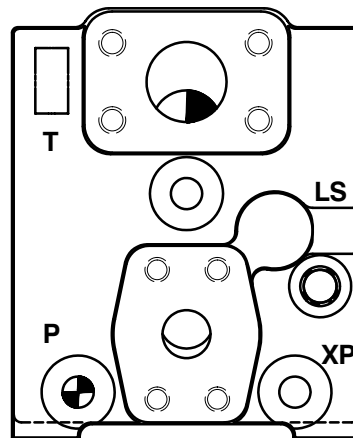

CMX160

Figure 7.

E. CMX160/100 Mid-Inlet 10.

The mid-inlet (Figure 8 and 9) facilitates the use of CMX160 and CMX100 valve sections in the same valve bank. The CMX160 sections are mounted on one side of the mid-inlet, and the CMX100 sections are mounted on the opposite side. System pressure and tank connections are made in the middle of the valve bank, rather than on the end.

Standard Mid-inlet

The standard mid-inlet (Figure 9) provides connections for pump, tank and external pilot supply (for electrohydraulic valves). Internal pilot supply is available by omitting a set screw plug in a connecting passage between the pump port and pilot supply passage, and plugging the external port. Load sense and external drain connections for mid-inlet valve banks must be made at the end covers.

Typical Mid-inlet Valve Bank

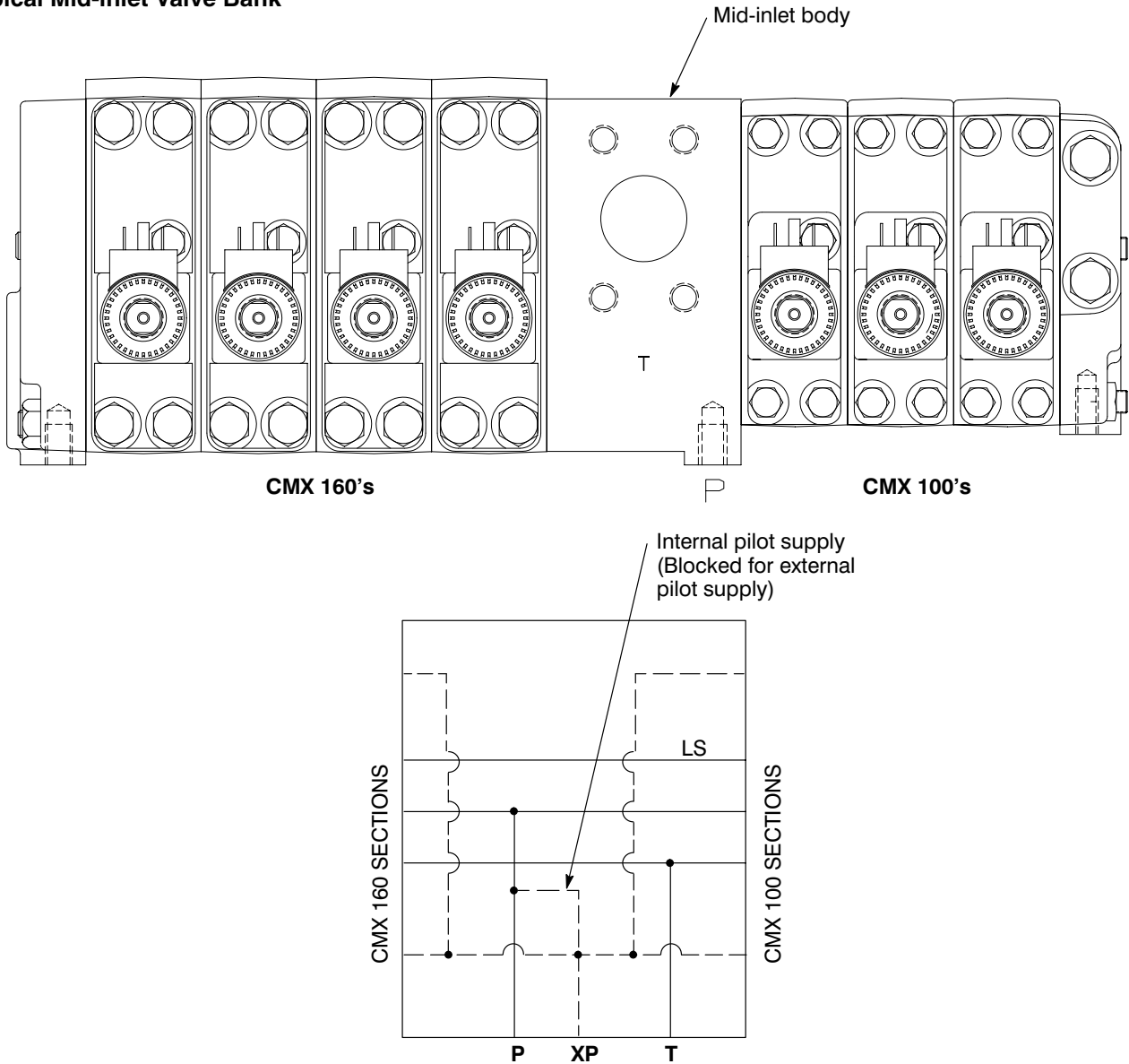

Figure 8. CMX100 & CMX160 Mid-Inlet

Mid-inlet with Reducing Valve and Anticavitation Make-up Flow

The mid-inlet can incorporate one or two reducing/relieving cartridges. This mid-inlet (Figure 9) incorporates two reducing/relieving cartridges to provide pilot supply pressure and tank port make-up flow. The reduced pilot supply pressure can be supplied internally to electrohydraulic sections and/or ported externally to HRC pilot supply ports. The tank port make-up flow is directed to the tank passage to maintain a minimum tank pressure under all operating conditions.

Make-up flow is an anticavitation feature. It is required in circuits where an overrunning load is causing an actuator to

move and draw more fluid from the tank port than is being returned by the opposite actuator port, and a check valve in the tank line prevents fluid from being drawn from tank. (A swing function powered by a hydraulic motor is a typical circuit that requires make-up flow.) The reducing valve should be set 0,69 bar (10 psi) below the back pressure check valve setting.

Valve banks incorporating a make-up flow cartridge require an external drain. External drain connections can be made at either of the end covers or the mid-inlet, and internal drains must be blocked. Load sense connections are made at the end covers.

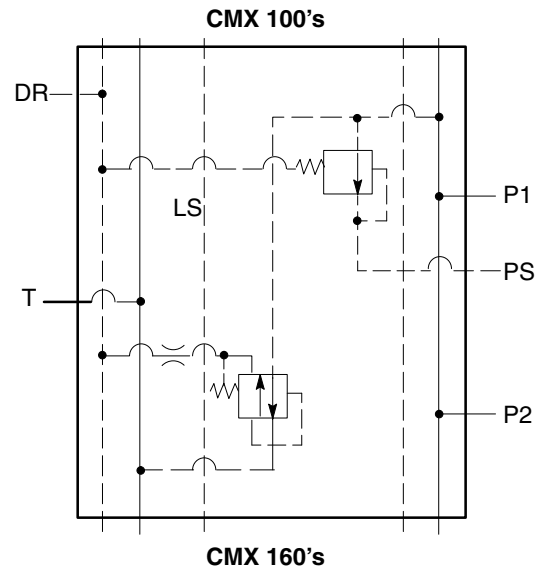
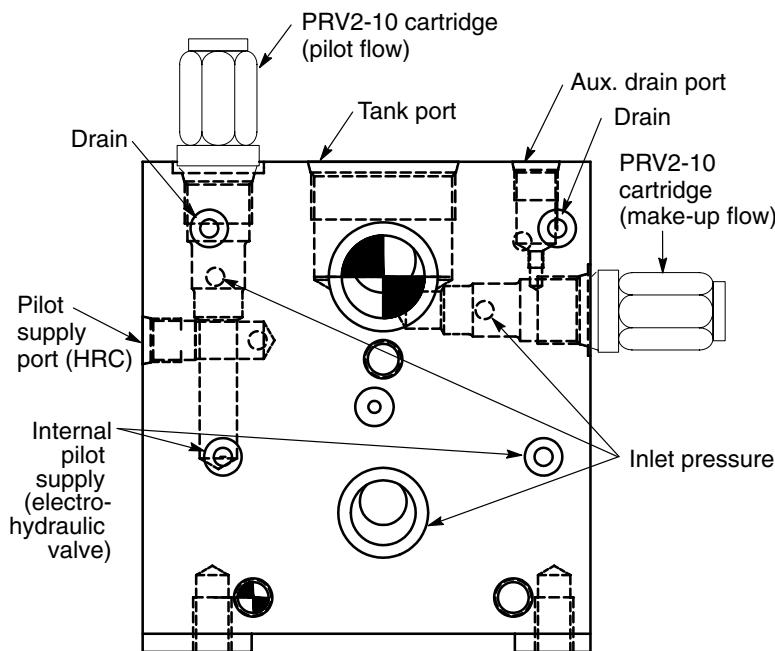

Standard pilot supply pressure is 28 bar (400 psi).

Make-up flow pressure options:

3,5 bar (50 psi)

7 bar (100 psi)

10,5 bar (150 psi)

Figure 9. CMX100 & CMX160 Mid-inlet

F. End Cover

An end cover (Figure 10) is required to terminate each valve bank. The end cover provides a passage that connects the control cap drain galleries from either side of the valve body.

Additionally, several optional features are located in the end cover:

| Optional Feature | Function |
|-----------------------------------|--|
| Internal/external drain: | Provides choice of internal or external drain. |
| Aux. load sense: | Provides load sense series connection for multiple valve banks. |
| Load sense decompression orifice: | Provides load sense decompression to drain via a 0.50 mm (.020") screened orifice. |
| Aux. "P" Port: | Augments "P" port in inlet body for special applications. |
| Aux. "T" Port: | Augments "T" port in inlet body for special applications. |

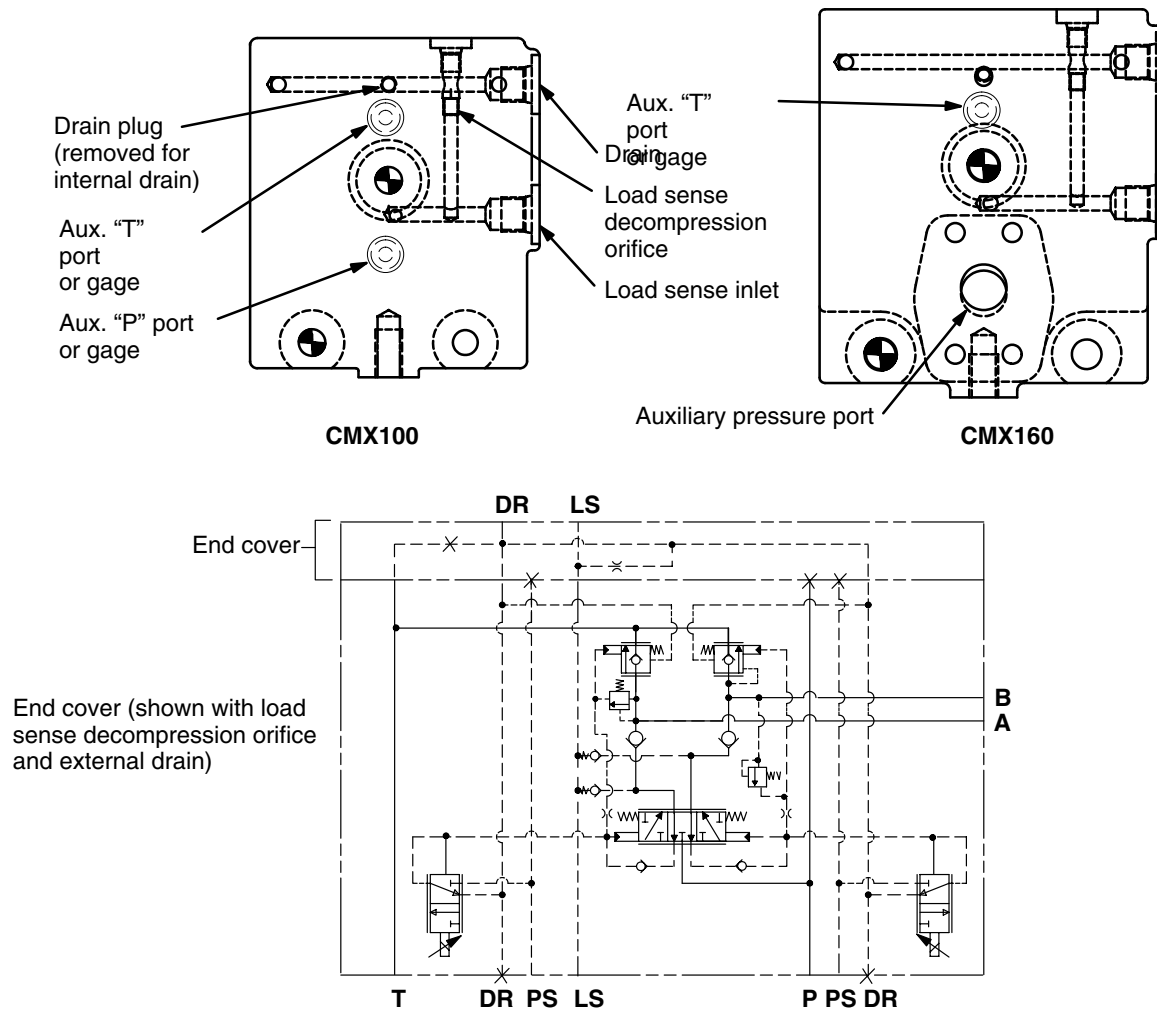

Figure 10. CMX100 & CMX160 End Covers

Section 3 - Principles of Operation

A. General 13.

The CMX valve system has three basic operational features. These features are called meter-in, meter-out and neutral. The meter-in feature is used to drive a load while the meter-out feature is used to lower a load. The neutral feature is used to hold a load in a desired position.

B. Operation of Valve Elements 14.

Meter-in/Meter-out Phasing

When the "06" meter-in spring is used, the meter-in element begins to open at a command pilot pressure of 6 bar (90 psi) and be fully open at 16,5 bar (240 psi). If a "12" meter-in spring is used, the meter-in element begins to open at 10 bar (150 psi) and is fully open at 21 bar (300 psi).

Normally the meter-out element will begin to open at a command pilot pressure of 3,5 bar (50 psi) and be fully open at 14 bar (200 psi).

The CMX valve meter-in meter-out pressures can be tailored to meet almost any requirement of the system by changing meter-in spring and meter-out poppet configurations. Consult your Vickers representative for further information concerning the capabilities of this valve subsystem.

Driving a Load

Pressurized oil from the pump is admitted through the meter-in spool to the load drop check valve. The load drop check opens and oil pressurizes actuator port "B" and one end of the cylinder. Oil from the other end of the cylinder is returned to the "A" actuator port and flows to tank (reservoir) through the meter-out element. Velocity of the oil and subsequent movement of the cylinder is controlled by the command pressure.

Lowering a Load

A load may be lowered when sufficient command pilot pressure is applied at the pilot port to partially open the meter-out element of the actuator port. Preload springs keep the meter-in spool in the center blocked condition. The load forces the cylinder rod to move. The opposite actuator port meter-out/anti-cavitation element opens, allowing the opposite side of the cylinder to fill with fluid. Return fluid flows to tank over the meter-out poppet which acts as a back pressure valve. Velocity of the cylinder can be controlled by varying control pressure, and in most cases it is not necessary to use the pump to power down the load, thus saving energy.

Neutral Position

When the CMX is in the neutral position, and actuator port pressure is below the relief valve setting, a load can be held stationary in one position. To keep the CMX valve in the neutral condition, the command pilot pressure at C1 and C2 must be below 3,5 bar (50 psi). When command pilot pressure is below 3,5 bar (50 psi), the meter-in spool is centered and the meter-out element is blocked. This load holding ability is due to the extremely low leakage between the meter-out poppets, compared to conventional spool valves.

Pump Standby Condition

When the meter-in spool is in the center position, the chamber drain opening through the spool allows pressure in the chamber to decay to atmospheric pressure. The pump control senses this pressure and causes the yoke to stroke to zero flow at minimum pressure. The pump will stay in the neutral (standby) condition until a demand from the controller is again felt at C1 or C2.

Section 4 - Installation & Operating Instructions

A. Hydraulic Tubing 16.

1. In a new or contaminated system, all tubing must be thoroughly cleaned before installation to remove dirt, rust and scale. Recommended methods of cleaning are sandblasting, wire brushing, pickling, and power flushing with clean solvent to remove loose particles.

NOTE

For information on pickling, refer to catalog 694.

2. To minimize flow resistance and the possibility of leakage, only as many fittings and connections as are necessary for proper installation should be used.
3. The number of bends in tubing should be kept to a minimum to prevent excessive turbulence and friction of oil flow. Tubing must not be bent too sharply. The recommended minimum radius for bends is three times the inside diameter of the tube. In high pressure systems, 345 bar (5000 psi) and above, use steel elbows instead of bending tubing to increase circuit life and reliability.

B. Hydraulic Fluid Recommendations 17.

General Data

Oil in a hydraulic system performs the dual function of lubrication and transmission of power. It constitutes a vital factor in a hydraulic system and should be carefully selected with the assistance of a reputable supplier. Proper selection of oil assures satisfactory life and operation of system components, with particular emphasis on hydraulic valves.

Any oil selected for use with valves is acceptable for use with pumps or motors. Oil recommendations noted in catalog 694 are based on our experience in industry as a hydraulic component manufacturer. Where special considerations indicate a need to depart from the recommended oils or operating conditions, see your Vickers sales representative.

Cleanliness

Observe the following precautions to insure the hydraulic system is clean:

1. For satisfactory service life of these components, maintain full flow filtration to provide fluid which meets ISO cleanliness code 17/15/13 or cleaner.
2. Filter each change of oil to prevent introduction of contaminants into the systems.
3. Provide continuous oil filtration to remove sludge and products of wear and corrosion generated during the life of the system.
4. Provide continuous protection of system from entry of airborne contamination by sealing the system and/or by proper filtration in the air breather.
5. During usage, proper oil filling and servicing of filter, breathers, reservoirs, etc. cannot be over emphasized.
6. For new vehicle start-up clean (flush) entire new system to ensure removal of any paint, metal chips, welding shot, etc.

Section 5 - Service & Maintenance

A. Inspection 19.

Periodic inspection of valve/system operation, oil condition and pressure connections saves time, resulting in fewer breakdowns and unnecessary part replacement. Major areas of concern are as follows:

1. All hydraulic connections must be tight. Loose connections not only allow leakage, but also permit air to be drawn into the hydraulic system. Air in the system causes noisy and erratic operation.
2. System filters and reservoir should be checked periodically for foreign particles. If excessive contamination is found, the system should be drained and cleaned. Install new system filters as necessary.

B. Adding Fluid to the System 20.

New hydraulic fluid usually contains particles of 50 microns or larger. When hydraulic fluid is added to a system, it must be filtered. In an emergency, if filtration is not available, a wire screen (200 mesh or better) can be substituted. It is important that the fluid be clean and free from all foreign substances. A contaminated system can cause improper operation and excessive wear to hydraulic components. Refer to Vickers literature #561, Systemic Contamination Control.

C. Replacement Parts 21.

Reliable operation throughout the specified operating range is assured only if genuine Vickers parts are used. Sophisticated design processes and materials are used in the manufacture of our parts. Substitutes may result in early failure.

Section 6 - Valve Bank Disassembly

A. General Information

CAUTION

Block vehicle if it is on a slope to prevent uncontrolled movement.

CAUTION

Before breaking a circuit connection, make certain that power is off and system pressure has been released. Lower all vertical cylinders, discharge accumulators, and block any load whose movement could generate pressure.

CAUTION

Absolute cleanliness is essential when working on a hydraulic system. Always work in a clean area. The presence of dirt and foreign materials in the system can result in serious damage or inadequate operations.

1. No special tools or fixtures are required.
2. Repair of the CMX valve will generally not require disassembly to the extent described here. The sequence can also be used as a guide for partial disassembly. Disassembly is shown in Figures 11 & 12. Special procedures are included in the following steps.
3. Before breaking a circuit connection, hose off or otherwise clean the outside of the unit thoroughly to prevent entry of dirt into the system.
4. If it is necessary to remove the CMX valve from the vehicle, make sure all ports and disconnected hydraulic lines are capped or plugged.
5. Discard and replace all O-rings and back-up rings that are removed during disassembly.

B. Disassembly of End Covers

CAUTION

During disassembly, particular attention should be given to identification of parts for assembly. DO NOT mix parts from each end of the body. Make sure all poppets and bores are marked at disassembly. Poppets develop a wear pattern and may leak if placed in a different bore.

The following steps pertain to the CMX100 & 160 models:

1. Remove the three M10 (CMX100) or M12 (CMX160) hex nuts from the end cover side of the valve bank.
2. Remove the end cover. Other than inspection of the fixed load sense decompression orifice, no further disassembly of the end cover is necessary.
3. Units supplied with mid-inlets will have two end covers. No additional disassembly of the standard mid-inlet is required.

4. Pull the three tie bolts through the remainder of the valve bank. No further disassembly of the inlet is required.
5. To assemble, reverse steps 1 through 3 and torque the tie bolts to 40 Nm (30 lb.ft.) for CMX100, or 70 Nm (52 lb.ft.) for CMX160.

A mid inlet is available with a reducing valve and anti-cavitation make-up flow valves. These cartridge valves may be removed from the inlet and replaced. No additional disassembly is required.

C. Control Cap & Internal Parts Removal

1. Remove the four (4) hex or socket head cap screws from each cover. Pull the cover straight away from the body approximately 25 mm to clear the piston. The only remaining parts in the cover are the relief pilot parts. No additional disassembly is required.

NOTE

The meter-out servo piston works in a bore machined into this cover.

With the control cap removed, meter-in springs can be exchanged. The meter-in element as well as the meter out poppets can be changed.

2. To remove the coil and core tube (electrohydraulic models only), remove the plastic knurled nut from the end of the core tube. Slide the coil off the core tube. To remove the core tube subassembly, unscrew the core tube counterclockwise.
3. With both control caps removed, all internal parts can be removed from the body except the load sense cartridges. These are bonded in place.
4. Take note of the direction the control cap gasket is installed prior to removing the control cap. Refer to gasket orientation shown in Figures 11 & 12.
5. If control cap is fitted with orifice plugs, do not remove these from body unless inspection reveals it is necessary. Orifices are bonded in place at the factory.
6. Disassembly of the meter-in element is not recommended.

NOTE

1. To change the meter-in or meter-out cracking, follow steps 1 and 2 to remove the control cap.
2. With the control cap removed, the meter-in springs can be readily exchanged.
3. To change the meter-out poppet, pry the meter-out servo stem subassembly from the body (see Figure 4) and remove the poppet. Install the desired poppet, replace the O-ring and back-up ring on the retainer, and press the retainer into the valve body.

D. Inspection, Repair, and Replacement

NOTE

All parts must be thoroughly cleaned and kept clean during inspection and assembly. The close tolerance of parts makes this requirement very important. Clean all removed parts using a commercial solvent that is compatible with the system fluid. Compressed air may be used in cleaning, but it must be filtered to remove water and contamination. Clean compressed air is particularly useful in cleaning end covers, valve body passages and orifices.

NOTE

Replace all parts that do not meet the following specifications.

1. Inspect all parts for wear, erosion and/or seizure.
2. Inspect all springs for parallelism. Spring ends must be parallel within 3°. Replace springs if worn or deformed.
3. Inspect all poppets for heavy wear patterns on the outside diameter of the poppet. Also, check poppet for the proper seating pattern. If the seating pattern is broken, check the main body bore and seat for erosion. If the body is eroded beyond repair, replace the valve. Poppets must move freely within their respective bores and have a close fit. If scratches are evident on the outside of the poppet, clean up with crocus cloth or 500 grit paper. If scratches are deep enough to cause heavy leakage, replace the poppet. Check the bore for identical scratches. Make sure scratches are not greater than 0,025 mm (0.001 inches) deep. If a poppet is replaced within the body, it must be seated to prevent excessive leakage. To seat a poppet, install the poppet in the bore and then insert a brass rod within the poppet and tap with a small hammer. The poppet will develop a ring around its contact point with the seat. This ring indicates a good sealing match between the poppet and seat. If the ring is not complete, recheck the seating area of the bore for distortion or erosion. Each poppet must seat properly within the bore for the valve to function within minimum leakage.
4. Check the meter-in spool for burrs and/or scratches. Clean up with an Arkansas stone. Do not stone sharp edges of the spool. Make sure the spool moves freely within the bore after clean up.
5. During valve assembly, the servo piston must move freely within the control cap. Make sure the stem is not bent and the point of contact of the stem within the meter-out poppet is clean and free from burrs.
6. Check all plugs and screws for broken threads and rounded corners. Replace parts that are defective.
7. Check the control cap gasket for signs of wear. Replace if necessary.

DO NOT FORCE the servo stem S/A into the control cap bore. The assembly must be assembled straight into the body and control cap.

E. Assembly

Obtain a seal kit for the unit being assembled.

Cover the entire assembly area with clean Kraft paper to prevent contamination of parts. Lubricate parts at assembly with system fluid. Use a viscosity improver, STP or equivalent for lubrication of seals. Assembly will be in reverse sequence as noted in disassembly.

| Model | Part | Torque |
|--------|-------------|--------------------|
| CMX100 | Control Cap | 30 Nm (22 lb. ft.) |
| CMX100 | Tie Bolt | 40 Nm (30 lb. ft.) |
| CMX160 | Control Cap | 54 Nm (40 lb. ft.) |
| CMX160 | Tie Bolt | 70 Nm (52 lb. ft.) |

F. Troubleshooting

| Operating Condition | Possible Problem Area |
|--|--|
| A. Raising Load | |
| 1. No response | a. No command pilot pressure |
| | b. Meter-out poppet stuck |
| | c. Meter-out stem jammed |
| | d. Meter-in spool stuck |
| | e. Meter-out poppet hung open |
| 2. Poor low speed control; jerky start | a. Binding meter-in spool |
| | b. Broken meter-in spring |
| 3. Top speed too low | a. Insufficient ΔP across meter-in spool |
| | b. Binding meter-in spool |
| | c. Insufficient pilot pressure ΔP between C1 and C2 ports |
| 4. Unstable | a. Pump failure |
| | b. Binding meter-in spool |
| | c. Unstable pump pressure |
| B. Lowering Load | |
| 1. No response | a. No command pilot pressure |
| | b. Meter-out stem jammed |
| | c. Binding meter-out poppet |
| | d. Lost or missing retaining ring in meter-out servo stem |
| 2. Poor low speed control; jerky start | a. Broken meter-out spring |
| | b. Binding meter-out piston in servo stem |
| 3. Lowering speed is uncontrollable | a. Broken meter-out stem |
| | b. Meter-out poppet stuck open |
| 4. Maximum speed too high | a. Due to high pressure resulting from heavy load. Operator control is required. |
| | b. Incorrect selection of meter-out poppet (install narrow notched poppet). |
| 5. Maximum speed too low | a. Jammed meter-out piston or poppet |
| | b. Incorrect selection of meter-out poppet (install wide notched poppet) |
| 6. Unstable | a. Binding meter-out piston or poppet |
| 7. Harsh stop; severe jolt | a. Binding meter-out piston or poppet |
| C. Holding Load | |
| 1. Slow downward drift | a. Load drop check valve not seating properly |
| | b. Relief valve has too much leakage |
| 2. Rapid downward drift | a. Load drop check cracked or defective seating area in body |
| | b. Relief valve poppet sticking |
| D. External Leakage | |
| | a. Damaged or missing seals |
| | b. Cracked body or end cover |
| | c. Mating surfaces between body/end covers not flat |
| | d. Burrs on mating surface |
| | e. Screws not torqued to specifications |

For additional information, consult Vickers CMX System Start-up and Troubleshooting Guide, literature number 592.

G. On-vehicle Test

CAUTION

Block vehicle to prevent any uncontrolled movement. Before opening the circuit, make certain that power is OFF and pressure has been released. Lower all vertical cylinders, discharge accumulators and block any load whose movement could generate pressure.

1. Install pressure gauges as appropriate. Refer to literature #592, CMX Start-up and Troubleshooting Guide.
2. Refer to the unit model code to determine "A" and "B" port relief pressure settings and meter-in cracking pressure.
3. Place all controls in the neutral or standby condition and start-up the vehicle.
4. Exercise the controls to eliminate air from the system. Warm-up the system fluid to approximately 120° F. Return the controls to neutral or stand-by condition.
5. If the CMX valve controls vehicle movement, block the vehicle. If the CMX valve controls cylinder movement, fully extend the cylinders. Move the appropriate control to build up pressure. Observe the pressure gauges.

NOTE

Pressure should be as noted in the model code. If pressure readings vary greatly from these requirements, a problem exists somewhere in the system.

6. After all tests are completed and the unit found to function normally, turn OFF power and release all pressure within the system. Remove pressure gauges and fittings. Replace the hex plugs and torque.

H. Adjusting Factory-preset Fixed Meter-out Port Relief Valve Pressure Setting

CAUTION

If the CMX valve is on the vehicle/machine, the procedure outlined in Section G above must be strictly followed before any adjustments to port relief pressure are initiated.

CAUTION

If the CMX valve has been removed from the valve, care must be taken to ensure that the test bench, hydraulic supply and circuit are suitable for operation at a minimum of at least 10% higher pressure capability than the higher of either the factory preset pressure or the new pressure to be set.

WARNING

The new port relief pressure must not exceed the rated pressures of 290 bar (4200 psi) for "S" operating sections and 380 bar (5510 psi) for "F/G/W" operating sections. Failure to comply with this limitation may result in failure of, or damage to, the operating section, which may cause bodily injury and/or damage to the vehicle/machine.

1. For electrohydraulic models, pages 24 and 25, Shim Kit "J" is the key part in the group of relief valve parts including H, I, J, K and L. For hydraulically actuated units, pages 26 and 27, Shim Kit "56" is the key part in the relief valve group of parts including 53, 54, 55, 56, 57 and 58. The location of the relief valve shims varies, dependent upon valve configuration. Refer to the illustrations below to assure proper assembly.

CMX100 hydraulically actuated valves and all valves with adjustable port relief valves. Refer to Figure 28 in Application Guide 536.

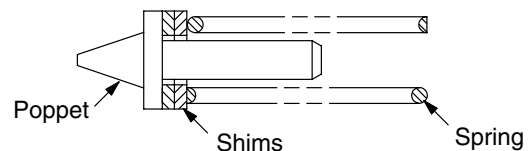

CMX100 electrohydraulically actuated, CMX160 hydraulically actuated, and CMX160 electrohydraulically actuated valves.

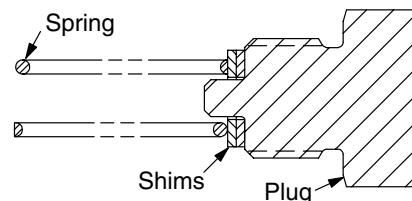

CMX100/160 hydraulically/electrohydraulically actuated meter-out pressure control valves. Refer to Figure 41 in Application Guide 536.

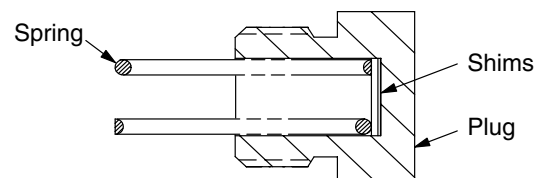

2. Ensure the CMX valve controls are in the neutral position, and start the vehicle/machine or test bench to obtain hydraulic flow through the circuit.
3. For requirements where the new desired pressure is greater than the existing relief valve pressure setting, set the pump compensator setting higher than this pressure. On the vehicle/machine, this is done by dead heading a cylinder and adjusting the pump compensator setting until the high pressure gage confirms the high pressure and the pump is no longer delivering flow. On a test rig, this is done by closing down on the load simulation valve and adjusting the pump compensator until the pressure gage confirms the higher pressure and the pump is no longer delivering flow.
4. When the new pressure setting is less than the existing relief valve pressure setting, there is no need to adjust the pump setting as installed on the vehicle/machine. If a test rig is being used, ensure the CMX valve is in the neutral position and, measuring with the high pressure gage, adjust the load simulation valve and pump compensator so there is no pump flow at a pressure that is higher than the new desired pressure.
5. Place the CMX valve in its neutral position and shut down the system while ensuring there is no trapped fluid pressure anywhere in the valve or system.
6. Remove plug "H" and o-ring "I" ("58" and "57" in hydraulically actuated units) to access shims "J" ("56" in order to make adjustments to the shim stack thickness to effect a change in the relief valve pressure. For "S, F and V" meter-out functions, a one thousandths of an inch change will change the factory preset pressure by 1.8 bar (25 psi). For the "P" meter-out function, this same change in shim stack thickness will cause a 2.1 bar (30 psi) change in pressure.

NOTE

Shim Kit 924029 consists of the following shims:

- 2 pieces, 25 thousandths of an inch (0.635 mm) thick;
- 2 pieces, 10 thousandths of an inch (0.254 mm) thick;
- 2 pieces, 2 thousandths of an inch (0.051 mm) thick.

NOTE

Any change to meter-out poppet gain will effect relief valve override. This is particularly true if the change is from a medium gain (model code "14") toward the more restrictive low gain (model code "56/90") poppet, or vice versa.

NOTE

It may take 2 or three iterations of shimming before obtaining the exact new desired pressure setting.

7. After changing the shim stack thickness to obtain the new desired pressure setting, replace the plug and o-ring (torque to 12.5–15.5 Nm/9.2–11.4 lb. ft.) and follow the procedure outlined in Section G to hydraulically verify the new relief valve pressure setting.
8. If the pump compensator setting has been changed, return it to its normal position using the procedure described in G5 to verify the original pump pressure setting.

WARNING

After any change made to the factory preset relief valve pressure setting, do not operate the vehicle/machine until the new pressure pressure setting has been hydraulically confirmed. Failure to do so may cause malfunction and/or damage to the vehicle/machine and may cause injury to personnel.

Adjusting Factory-preset Adjustable Meter-out Port Relief Valve Pressure Setting 31.

WARNING

All Caution and Warning notes in Section H above apply to this section!

NOTE

All CMX operating sections with adjustable port relief valve are factory preset at 210 bar (3000 psi). Adjustment sensitivity is 53 +/- 5 bar (750 +/- 75 psi) per turn.

Follow the procedures outlined in Section G, using item 5 as the guideline, to observe the high pressure gage for the setting of the new desired pressure setting by adjusting the adjustment screw (part "8", page 28). Refer to section drawings (Figure 4, page 9 and Figure 6, page 10) for illustrations of the optional Adjustable Port Relief Valve.

CMX 100/160 Valve Section

Model Code

CMX 100 - F 3 - A S D 0 06 -S 03 C 25 - B S D 0 12 - S 14 C 28 -E G U0 - 25

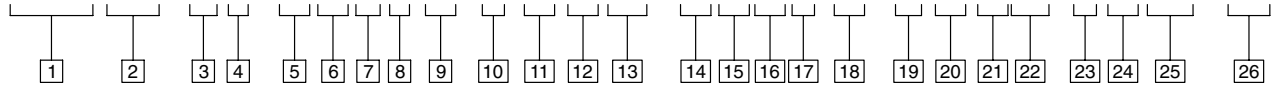

| | | |
|---|---|---|
| 1 Valve Series Load sensing Pressure compensated | 9 Meter-in Cracking Pressure 06 – 6.3 bar (90 psi) 12 – 11.6 bar (168 psi) | 14 Port Designation “B” |
| 2 Valve Series 100 – 100 l/min (26 USgpm) rated flow 160 – 160 l/min (42 USgpm) rated flow | 10 Meter-out Function S – Standard P – Pressure control (must have external drain). When P is designated in position 10 & position 19, positions 11 & 20 must be “03” for a CMX100 and “04” for a CMX160. F – Free coast M – Meter-out spool - fully open to tank in neutral (CMX100 only) N – Meter-out spool - restricted opening to tank in neutral (CMX100 only) V – Standard with externally vented port relief | 15 - 22 Repeat positions 6-13 for positions 15-22 Equivalent positions (6 & 15) and (7 & 16) must be identical designators. Also, positions 10 & 19 must be identical when a meter-out spool is required. |
| 3 Port Configuration S – Threaded port SAE O-ring connection W – Wide body threaded port SAE O-ring connection F – Flanged port Code 62 SAE 4-bolt high pressure G – Flanged port Code 61 SAE 4-bolt standard pressure | 11 Meter-out Element (ΔP @ rated flow) 00 – Meter-out spool, CMX100 only 03 – 3 bar (44 psi), CMX100 only 04 – 4 bar (58 psi), CMX160 only 07 – 7 bar (102 psi), CMX160 only 14 – 14 bar (203 psi) 56 – 56 bar (812 psi), CMX160 only 90 – 90 bar (1305 psi), CMX100 only | 23 Actuation E – Electrohydraulic H – Hydraulic (must have external drain in end cover) |
| 4 Construction 2 – Sectional 3 – Sectional with module (requires F or G ports). See code position 12 for module designator. | 12 Meter-out Special Features (Leave blank when module is not required.) A – Anti-cavitation valve T to A B – Anti-cavitation valve T to B C – Anti-cavitation valve T to AB H – High flow module (requires high flow meter-in function) | 24 Solenoid Voltage (Electrohydraulic actuation only – leave blank for hydraulic actuation.) G – 12 V DC H – 24 V DC |
| 5 Port Designation “A” | 13 Meter-out Port Relief (Relief setting) 00 – Without pilot relief 10-38 – Consecutive numbers representing 100 bar (1450 psi) to 380 bar (5512 psi) in increments of 10 bar (150 psi) e.g. 14 is 140 bar. 99 – Externally adjustable relief** (factory set to 207 bar (3000 psi)). | 25 Electrical Connectors (Leave blank for hydraulic actuation.) FL – Flying leads U0 – DIN 43650 Spade plug only U1 – DIN 43650 Complete MP – Metri-pack® |
| 6 Meter-in Function S – Standard P – Standard with pressure limitation, CMX100 only L – Low flow, 0-40 l/min (0-11 USgpm), CMX100 only H – Single acting high flow (up to twice rated flow) | 7 Meter-in Designators N – No vents in meter-in spool D – Vented meter-in spool (standard) | 26 Design Number |
| 8 Pressure Feedback Piston Dia.* 0 – No piston (flow control spool) 2 – 1.6 mm (pressure control spool) 4 – 3.6 mm (pressure control spool) CMX100 only 5 – 4.5 mm (pressure control spool) CMX160 only | | * When a pressure feedback piston is indicated in positions 8 & 17 together with a “P” in positions 10 & 19, relief settings below 140 bar (2030 psi) will result in excessive leakage. ** Not available with pressure control meter-out; i.e. P03*99 and P04*99 are not possible. |

CMX Sectional Valve Bank

Model Code

CMX 100 - S E - SFS - F T X - M - 25 - Assy. number

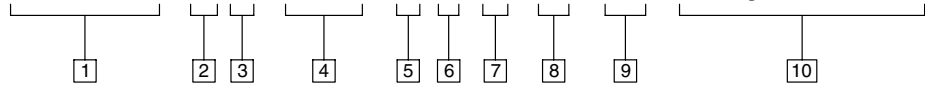

| Valve Series | PC** – Inlet body with pressure reducing valve and anticavitation make-up flow – CMX100 only – SAE straight thread | 5 End Cover |
|--|---|---|
| 2 Inlet (See page 5 for port sizes.) S – SAE straight thread – CMX100 only F – SAE 4-bolt flange, Code 62, CMX160 only G – SAE 4-bolt flange, Code 61, CMX160 only L – Load sense inlet – CMX100 only – SAE straight thread ** Load sensing pressure differential in bar 10 – 10 bar (145 psi) 16 – 16 bar (232 psi) 26 – 26 bar (377 psi) * Unloading solenoid valve, flying leads only N – None G – 12 VDC H – 24 VDC ** Unloading relief valve setting: With solenoid valve; Range 10–210 bar (145–3000 psi) Range codes 01–21 × 10 = pressure setting in bar. Example: L16G18 Without solenoid valve; Range 10–250 bar (145–3625 psi) Range codes 01–25 × 10 = pressure setting in bar. Example: L16N24 | 10 – Pressure reducing valve only. Standard setting is 28 bar (400 psi). 2* – Make-up flow valve only. Indicate desired pressure setting; e.g., 2B. A – 3,5 bar (50 psi) B – 7 bar (100 psi) C – 10,5 bar (150 psi) 3* – Both pressure reducing valve – 28 bar (400 psi) – and make-up flow valve. Indicate desired pressure setting with appropriate letter as shown above; e.g., 3A. Examples: CMX100-PC10 CMX100-PC2B CMX100-PC3C | C – Without LS (load sense) port, LS decompression orifice or external relief vent port F – With LS port and 0,5 mm (0.020 in.) LS decompression orifice L – With LS port only VV – With LS port and external relief vent port. Only used with “V” meter-out function. |
| | 3 Pilot Supply H – Hydraulic N – Internal pilot supply – electrohydraulic E – External pilot supply – electrohydraulic | 6 Auxiliary Ports in End Cover (See page 5 for port sizes.) P – Aux. P port T – Aux. T port or gage port S – Aux. P & T ports |
| | 4 Operating Section One required for each section, up to eight sections. Letter indicates section port configuration; i.e., S, W, F or G. | 7 Drain (end cover) X – External drain port open N – Internally drained |
| | | 8 Mounting Holes U – Inch threads M – Metric threads See page 5 for thread sizes. |
| | | 9 Design Number |
| | | 10 Assembly Number Assigned by Vickers |

CMX Mid-Inlet Sectional Valve Bank

Model Code

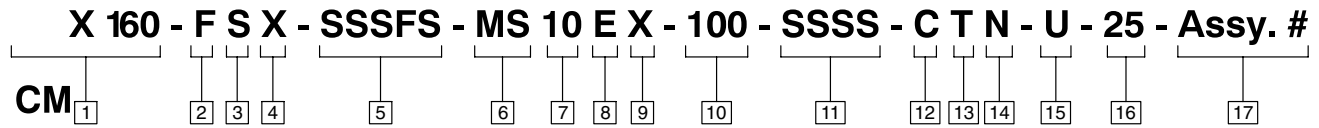

CMX160 Valve Series

2 End Cover (CMX160)

- C – Without LS (load sense) port, LS decompression orifice or external relief vent port
- F – With LS port and 0,5 mm (0.020 in.) LS decompression orifice
- L – With LS port only
- V – With LS port and external relief vent port. Only used with “V” meter-out function.

Auxiliary Ports in End Cover

- P – Auxiliary “P” port
- T – Auxiliary “T” port or gage port
- S – Auxiliary “P & T” ports

Drain

(CMX160 end cover)

- X – External drain port open
- B – Blocked drain (both internal & external drains plugged)
- N – Internally drained

Valve Operating Section (CMX160)

One letter required per section, up to 8 sections. Letter indicates valve section port configurations; i.e., S, W, F or G.

6 Mid-inlet*

- MS – SAE straight thread ports with provision for cartridge valves
- MG – SAE 4-bolt flange ports (code 61) with no provision for cartridge valves

7 Mid-inlet Cartridge Valve(s)

- 00 – No cartridge valves
- 10 – Pilot supply valve. Standard setting is 28 bar (400 psi).
- 2* – Make-up flow valve pressure setting. Indicate desired setting, e.g., 2B.
 - A - 3,5 bar (50 psi)
 - B - 7 bar (100 psi)
 - C - 10,5 bar (150 psi)
- 3* – Pilot supply valve – 28 bar (400 psi) – and make-up flow valve (Indicate desired pressure setting with appropriate letter as shown above; e.g., 3A).

8 Pilot Supply for Hydraulic Remote Controllers

- E – External pilot port open
- H – External pilot port plugged

9 Drain

(mid-inlet)

- X – External drain port open (MS mid-inlet only)
- B – Blocked drain (both internal & external drains plugged)

10 CMX100 Valve Series

11 Valve Operating Section (CMX100)

One letter required per section, up to 8 sections. Letter indicates valve section port configuration; i.e., S, W, F or G.

12 End Cover (CMX100)

- C – Without LS (load sense) port, LS decompression orifice or external relief vent port
- F – With LS port and 0,5 mm (0.020 in.) LS decompression orifice
- L – With LS port only
- V – With LS port and external relief vent port. Only used with “V” meter-out function.

13 Auxiliary Ports in End Cover

- P – Auxiliary “P” port
- T – Auxiliary “T” port or gage port
- S – Auxiliary “P & T” ports

14 Drain

(CMX100 end cover)

- X – External drain port open
- B – Blocked drain (both internal & external drains plugged)
- N – Internally drained

15 Mounting Holes

- U – Inch thread size. End covers, 1 hole each. Mid-inlet, 2 holes.
- M – Metric thread size. End covers, 1 hole each. Mid-inlet, 2 holes.

16 Design Number

17 Assembly Number

Assigned by Vickers

* MG mid-inlet can be internally or externally piloted. MS mid-inlet *must* be either externally piloted or include a pilot supply valve.

CMX Electrohydraulic Exploded View

| Item | Qty | Description | Item | Qty | Description |
|------|-----|--|------|-----|---|
| 1 | (3) | Nut (torque 36-44 Nm (26.5-32.4 lb.ft.)) | 17 | (6) | Plug (torque 9,8-10,2 Nm (7.2-7.5lb.ft.)) |
| 2 | | End cover | 18 | (6) | O-ring |
| 3 | (2) | Plug (torque 29-32 Nm (21.4-23.6 lb.ft.)) | 19 | | Plug (torque 29-32 Nm (21.4-23.6 lb.ft.)) |
| 4 | (2) | O-ring | 20 | | O-ring |
| 5 | | Plug (torque 9,7-10,2 Nm (7.2-7.5 lb.ft.)) | 21 | | PRV2-10-F-0-20/4 |
| 6 | | O-ring | | | (torque 46,9-53,9 Nm (34.6-39.8 lb.ft.)) |
| 7 | (5) | Nut (torque 62,9-77 Nm (46.4-56.8 lb.ft.)) | 22 | | PRV2-10-F-0-3/0.5 |
| 8 | | Tie rod | | | (torque 46,9-53,9 Nm (34.6-39.8 lb.ft.)) |
| 9 | | Tie rod | 23 | | S/A Mid-inlet body (item 43 omitted when mid-inlet is used) |
| 10 | | Plug (torque 29-32 Nm (21.4-23.6 lb.ft.)) | 24▲ | | O-ring |
| 11 | | O-ring | 25▲ | (5) | O-ring |
| 12 | | End cover (item 43 omitted when mid-inlet is used) | 26▲ | | O-ring |
| 13 | | Plug (gage) (torque 12-12,3 Nm (8.9-9.1 lb.ft.)) | 27△ | | O-ring |
| 14 | | O-ring | 28△ | (5) | O-ring |
| 15 | | Plug (torque 29-32 Nm (21.4-23.6 lb.ft.)) | 29△ | | O-ring |
| 16 | | O-ring | | | |

The following items make up the stem servo S/A:

| | | |
|----|-----|--|
| 30 | (2) | Stem |
| 31 | (2) | Seat |
| 32 | (2) | Spring |
| 33 | (2) | Washer |
| 34 | (2) | O-ring |
| 35 | (2) | Retainer |
| 36 | (2) | O-ring |
| 37 | (2) | Back-up ring |
| 38 | (2) | Retainer |
| 39 | (2) | Piston |
| 40 | (2) | Head |
| 41 | (2) | O-ring |
| 42 | (2) | Retaining ring |
| 43 | | Standard inlet (items 12 and 23 omitted when using standard inlet) |
| 44 | | Plug |

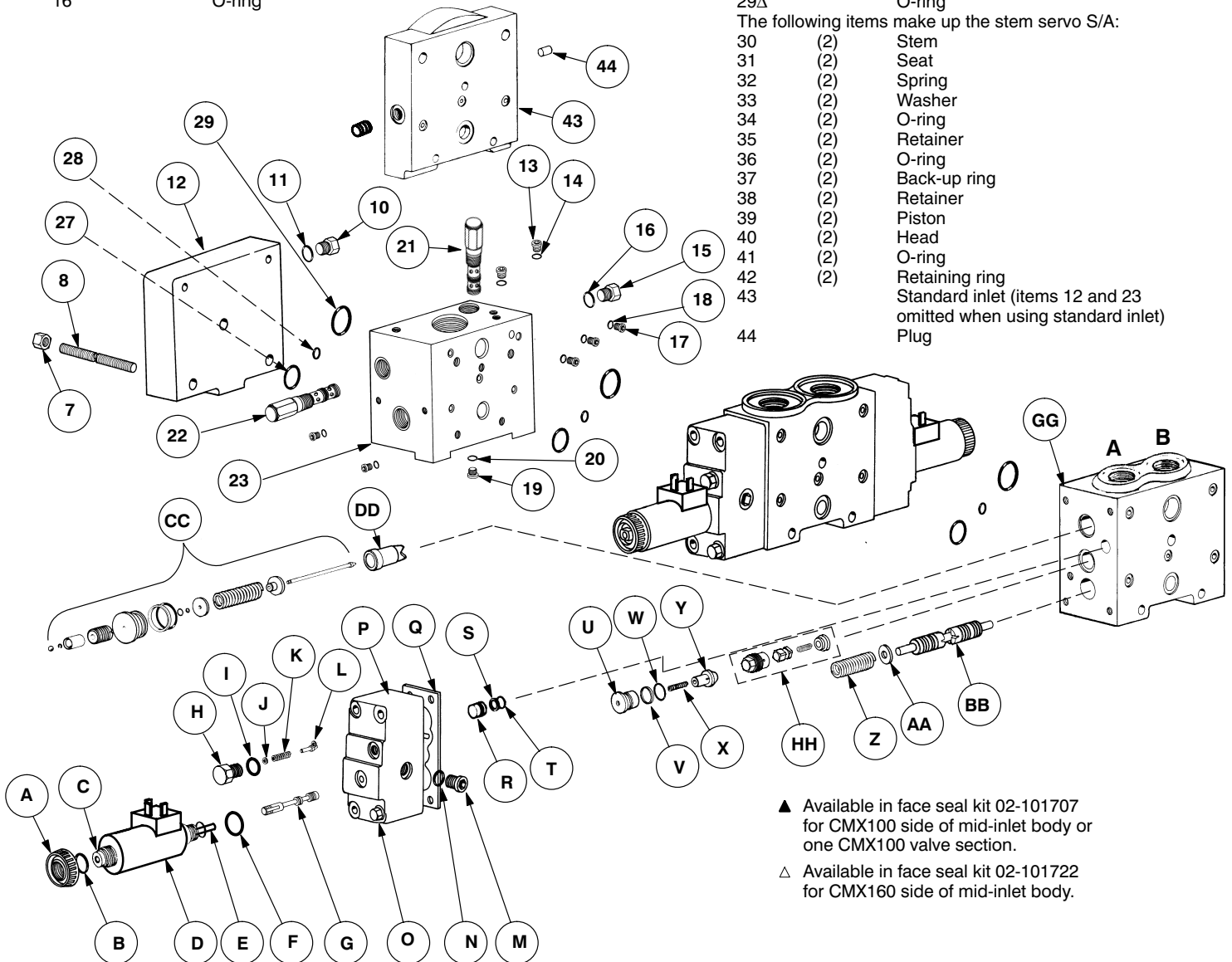

- ▲ Available in face seal kit 02-101707 for CMX100 side of mid-inlet body or one CMX100 valve section.
- △ Available in face seal kit 02-101722 for CMX160 side of mid-inlet body.

Figure 11. CMX Electrohydraulic Valve Bank Exploded View

| Item | Qty | Description | Item | Qty | Description |
|------|-----|---|------|-----|---|
| A | (2) | Coil nut (hand tighten) | U | (2) | Retainer |
| B | (2) | O-ring | V | (2) | Back-up ring |
| C | (2) | S/A Core tube (includes item FF) (torque 12,8-19 Nm (9.5-14 lb.ft.)) | W | (2) | O-ring |
| D | (2) | Coil | X | (2) | Spring |
| E | (2) | Pin | Y♦ | (2) | Poppet (with .75 mm orifice on A port side only) |
| F | (2) | O-ring | Z | (2) | Spring |
| G | (2) | Spool (assemble with long land toward coil) | AA | (2) | Retainer |
| H | (2) | Plug (torque 12,5-15,5 Nm (9.2-11.4 lb.ft.)) | BB | (2) | S/A Spool |
| I | (2) | O-ring | CC▪ | (2) | S/A Stem servo (consists of items 30-42) |
| J* | (2) | Shim kit | DD♦ | (2) | Poppet |
| K | (2) | Spring | EE♦ | (2) | Poppet (without orifice on B port side only) |
| L♦ | (2) | Poppet | FF | (2) | O-ring |
| M | (2) | Plug (torque 6-8 Nm (4.4-5.9 lb.ft.)) | GG | (2) | S/A Body |
| O | (8) | Bolt (torque 27-32,9 Nm (19.9-24.3 lb.ft.)) | HH | (2) | S/A Load sense check cartridge Adjustable relief S/A |
| P● | (2) | Control cap | KK | (2) | O-ring |
| Q | (2) | Gasket (install with embossed ridges facing coil) | LL | (2) | Retainer |
| R | (2) | Seat | MM | (2) | Spring |
| S | (2) | Back-up ring | NN | (2) | Poppet |
| T | (2) | O-ring | | | |

▪ Individual stem servo parts not available for sale.
Order complete stem servo.

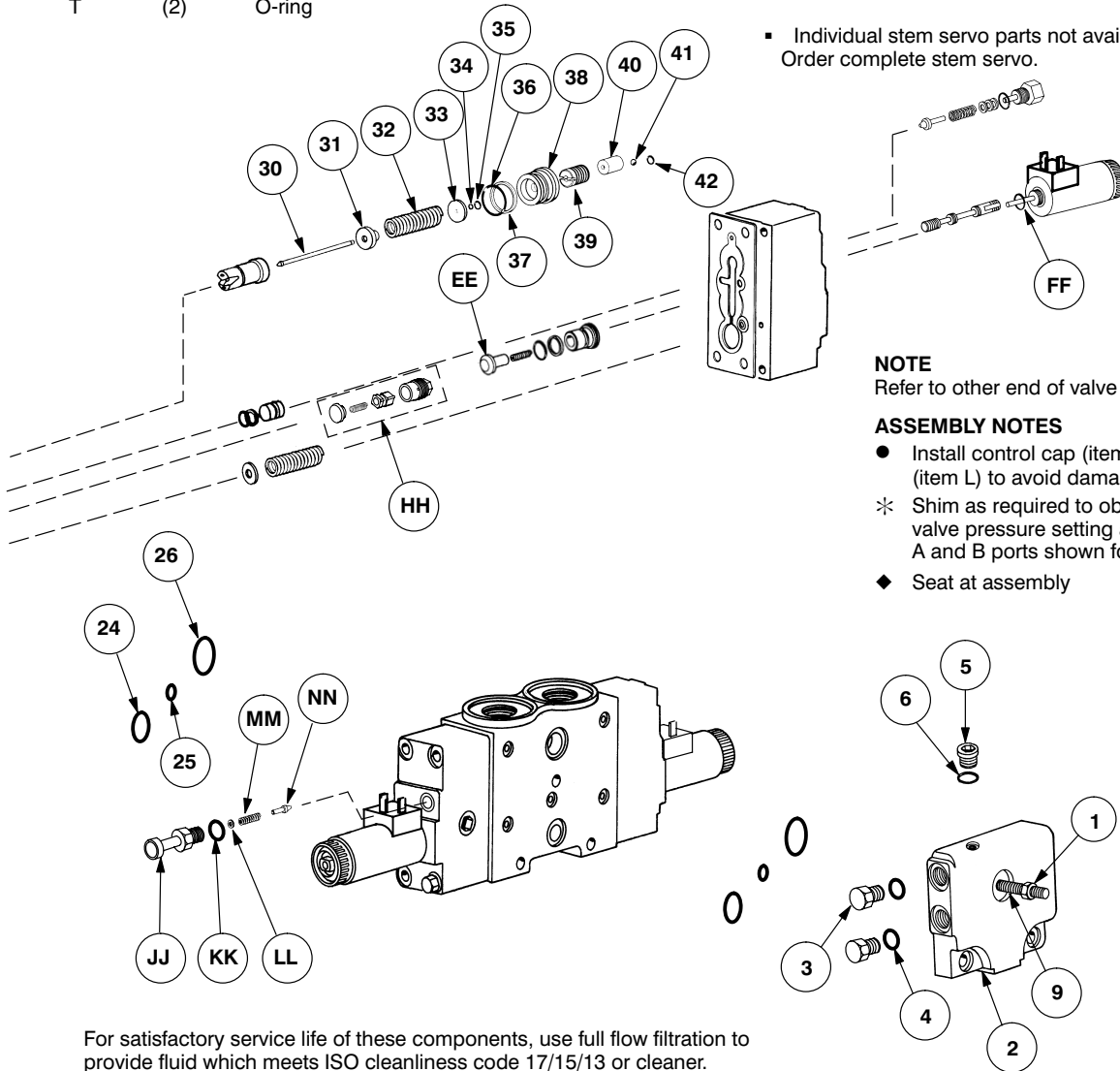

NOTE
Refer to other end of valve for item letters except as noted.

ASSEMBLY NOTES

- Install control cap (item P) prior to poppet (item L) to avoid damage to seat (item R).
- * Shim as required to obtain correct relief valve pressure setting at A & B ports. A and B ports shown for reference only.
- ♦ Seat at assembly

For satisfactory service life of these components, use full flow filtration to provide fluid which meets ISO cleanliness code 17/15/13 or cleaner. Selections from pressure, return, and in-line filter series are recommended.

CMX Hydraulic Actuation Exploded View

| Item | Qty | Description | Item | Qty | Description |
|------|-----|--|------|-----|--|
| 1 | (3) | Nut (torque 36-44 Nm (26.5-32.4 lb.ft.)) | 17 | (2) | Gasket (install with embossed ridges facing coil) |
| 2 | | End cover (item 38 omitted when mid-inlet is used) | 18 | (2) | Retainer |
| 3 | | Tie rod | 19 | (2) | Back-up ring |
| 4 | (2) | Plug (torque 29-32 Nm (21.4-23.6 lb.ft.)) | 20 | (2) | O-ring |
| 5 | (2) | O-ring | 21 | (2) | Spring |
| 6 | | Plug (torque 9,7-10,2 Nm (7.2-7.5 lb.ft.)) | 22 | (2) | Poppet (with .75 mm orifice on A port side only) |
| 7 | | O-ring | 23 | (2) | Spring |
| 8 | (2) | Adjustment screw | 24 | (2) | Retainer |
| 9 | (2) | Plug | 25 | | S/A Spool |
| 10 | (2) | O-ring | 26 | (2) | O-ring |
| 11 | (2) | O-ring | 27 | (2) | Back-up ring |
| 12 | (2) | Piston | 28 | (2) | Seat |
| 13 | (2) | Spring | 29 | (2) | S/A Load sense check cartridge |
| 14 | (2) | Poppet | 30 | (2) | S/A Stem servo |
| 15 | (8) | Bolt (torque 27-32,9 Nm (19.9-24.3 lb.ft.)) | 31 | (2) | Poppet |
| 16 | (2) | Control cap | 32 | (3) | Nut (torque 36-44 Nm (26.5-32.4 lb.ft.)) |
| | | | 33 | | End cover (item 38 omitted when mid-inlet is used) |
| | | | 34 | | O-ring |
| | | | 35 | (5) | O-ring |
| | | | 36 | | O-ring |
| | | | 37 | | Plug (torque 29-32 Nm (21.4-23.6 lb.ft.)) |
| | | | 38 | | Standard inlet (items 33 and 49 omitted when using standard inlet) |

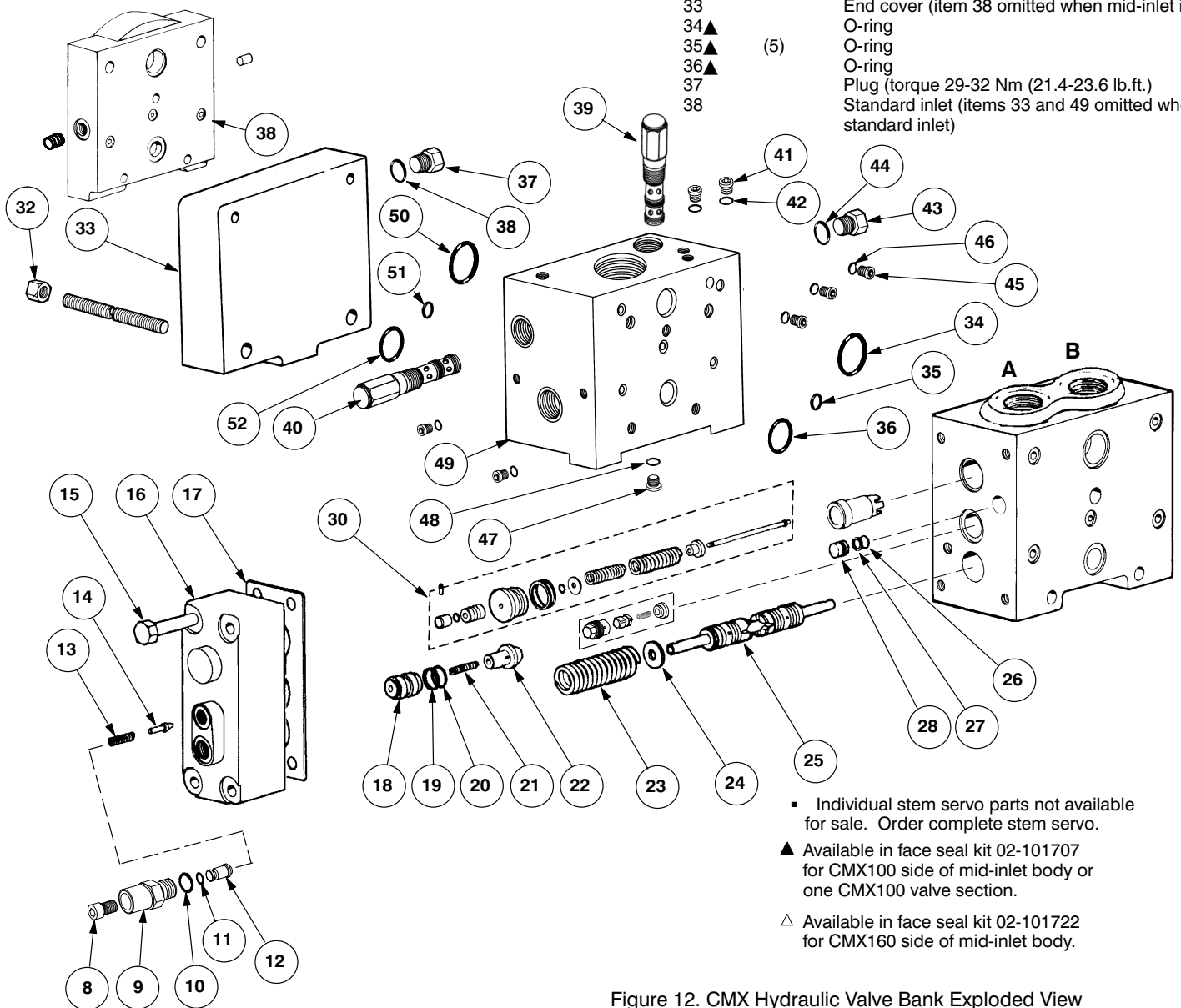

- Individual stem servo parts not available for sale. Order complete stem servo.
- ▲ Available in face seal kit 02-101707 for CMX100 side of mid-inlet body or one CMX100 valve section.
- △ Available in face seal kit 02-101722 for CMX160 side of mid-inlet body.

Figure 12. CMX Hydraulic Valve Bank Exploded View

| Item | Qty | Description |
|------|-----|---|
| 39 | | PRV2-10-F-0-20/4 (torque 46,9-53,9 Nm (34.6-39.8 lb.ft.)) |
| 40 | | PRV2-10-F-0-3/0.5 (torque 46,9-53,9 Nm (34.6-39.8 lb.ft.)) |
| 41 | | Plug (gage) (torque 12-12,3 Nm (8.9-9.1 lb.ft.)) |
| 42 | | O-ring |
| 43 | | Plug (torque 29-32 Nm (21.4-23.6 lb.ft.)) |
| 44 | | O-ring |
| 45 | (6) | Plug (torque 9,8-10,2 Nm (7.2-7.5 lb.ft.)) |
| 46 | (6) | O-ring |
| 47 | | Plug (torque 29-32 Nm (21.4-23.6 lb.ft.)) |
| 48 | | O-ring |
| 49 | | S/A Mid-inlet body (item 38 omitted when mid-inlet is used) |
| 50Δ | | O-ring |
| 51Δ | (5) | O-ring |
| 52Δ | | O-ring |
| 53 | | Poppet |
| 54 | | Piston |
| 55 | | Spring |
| 56 | | Shim kit |
| 57 | | O-ring |
| 58 | | Plug (torque 13,6-16,3 Nm (10-12 lb. ft.)) |
| 59 | | O-ring |

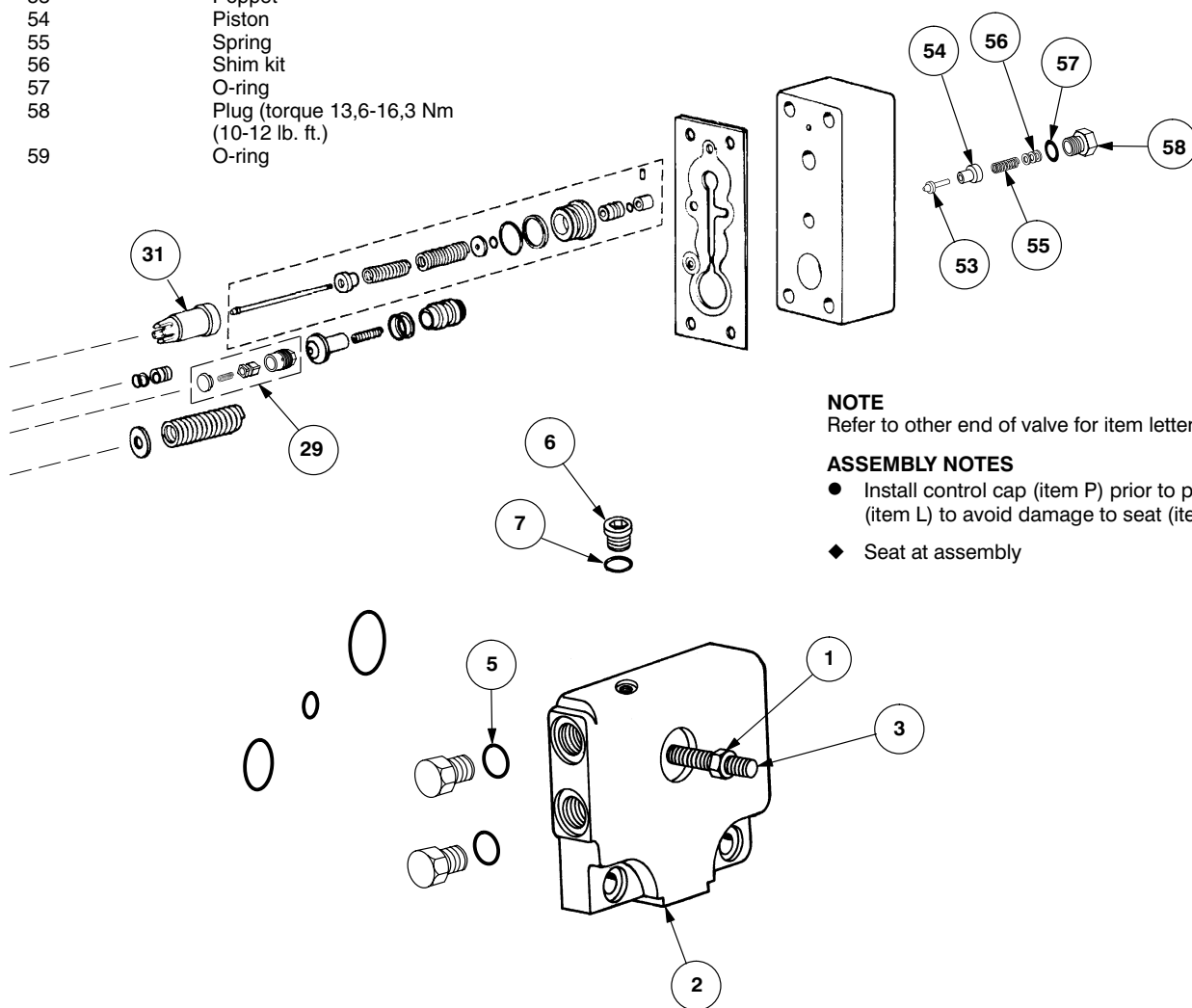

NOTE
Refer to other end of valve for item letters except as noted.

- ASSEMBLY NOTES**
- Install control cap (item P) prior to poppet (item L) to avoid damage to seat (item R).
 - ◆ Seat at assembly

For satisfactory service life of these components, use full flow filtration to provide fluid which meets ISO cleanliness code 17/15/13 or cleaner. Selections from pressure, return, and in-line filter series are recommended.

Fluid Cleanliness

Proper fluid condition is essential for long and satisfactory life of hydraulic components and systems. Hydraulic fluid must have the correct balance of cleanliness, materials and additives for protection against wear of components, elevated viscosity and inclusion of air.

Essential information on the correct methods for treating hydraulic fluid is included in Vickers publication 561; "Vickers Guide to Systemic Contamination Control," available from your local Vickers distributor or by contacting Vickers, Incorporated. Recommendations on filtration and the selection of products to control fluid condition are included in Vickers publication 561.

Recommended cleanliness levels, using petroleum oil under common conditions, are based on the highest fluid pressure

levels in the system and are coded in the chart below. For fluids other than petroleum, severe service cycles or temperature extremes are cause for adjustment of these cleanliness codes. See **Vickers publication 561** for exact details.

Vickers products, as any components, will operate with apparent satisfaction in fluids with higher cleanliness codes than those described. Other manufacturers will often recommend levels above those specified. Experience has shown, however, that life of any hydraulic components is shortened in fluids with higher cleanliness codes than those listed below. These codes have been proven to provide a long trouble-free service life for the products shown, regardless of the manufacturer.

| SYSTEM PRESSURE LEVEL | | | |
|------------------------------|-------------------|--------------------|----------------------|
| PRODUCT | 70 bar (1000 psi) | 140 bar (2000 psi) | 210+ bar (3000+ psi) |
| Vane Pumps – Fixed | 20/18/15 | 19/17/14 | 18/16/13 |
| Vane Pumps – Variable | 18/16/14 | 17/15/13 | |
| Piston Pumps – Fixed | 19/17/15 | 18/16/14 | 17/15/13 |
| Piston Pumps – Variable | 18/16/14 | 17/15/13 | 16/14/12 |
| Directional Valves | 20/18/15 | 20/18/15 | 19/17/14 |
| Pressure/Flow Control Valves | 19/17/14 | 19/17/14 | 19/17/14 |
| CMX Valves | 18/16/14 | 18/16/14 | 17/15/13 |
| Servo Valves | 16/14/11 | 16/14/11 | 16/13/10 |
| Proportional Valves | 17/15/12 | 17/15/12 | 15/13/11 |
| Cylinders | 20/18/15 | 20/18/15 | 20/18/15 |
| Vane Motors | 20/18/15 | 19/17/14 | 18/16/13 |
| Axial Piston Motors | 19/17/14 | 18/16/13 | 17/15/12 |
| Radial Piston Motors | 20/18/14 | 19/17/13 | 18/16/13 |

Eaton Hydraulics

15151 Highway 5
Eden Prairie, MN 55344
Telephone: 612 937-7254
Fax: 612 937-7130
www.eatonhydraulics.com

46 New Lane, Havant
Hampshire PO9 2NB
England
Telephone: (44) 170-548-6451
Fax: (44) 170-548-7110

