

Service Data

Vickers®

Piston Motors



Fixed Inline Piston Motor

M-MFB15-15

Foot Mounting Bracket
Model M-MFB*-f-31**

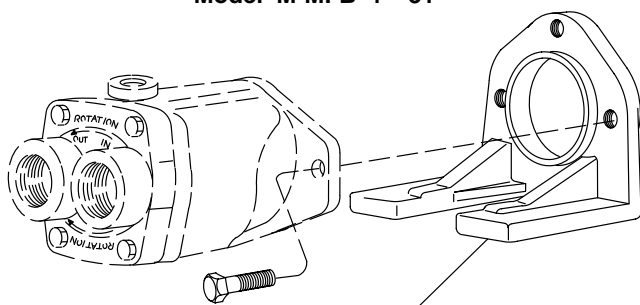

Mounting Kit FB-B-10
 (Includes Screws)

Model	Valve Plate S/A (Includes 12016 Bearing)
M-MFB15-U*-31	922995

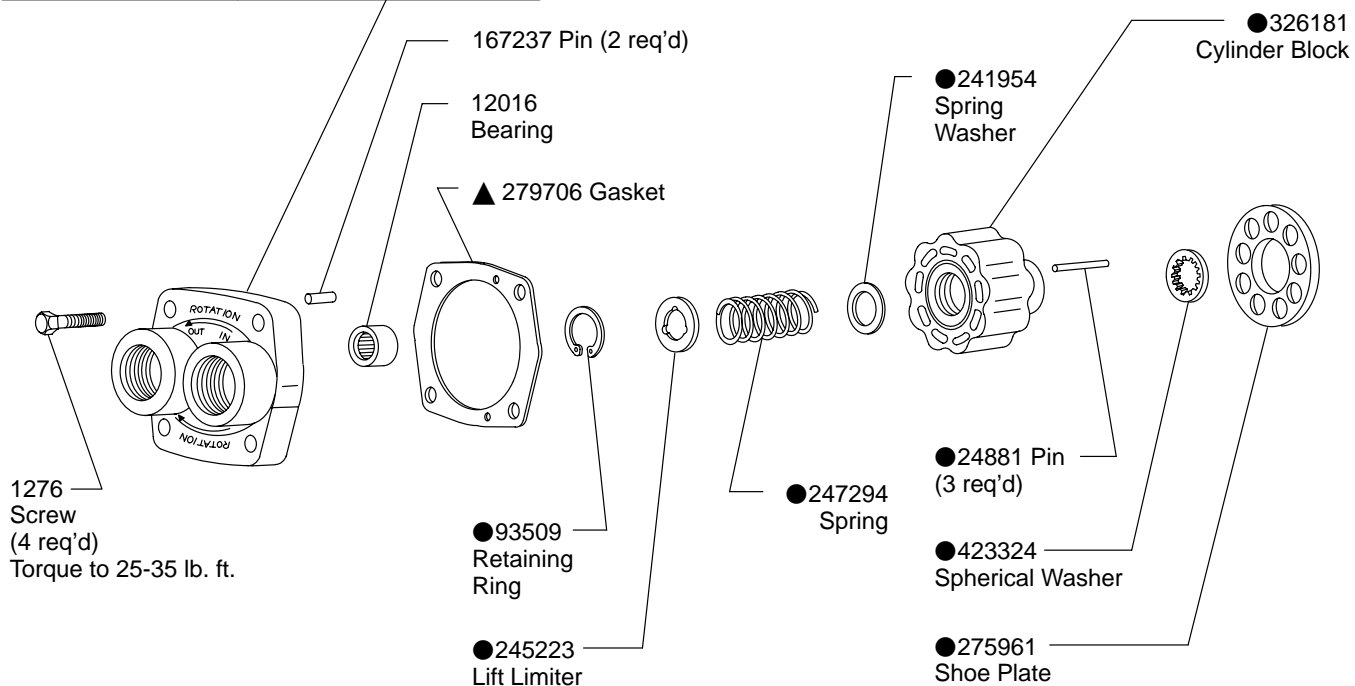

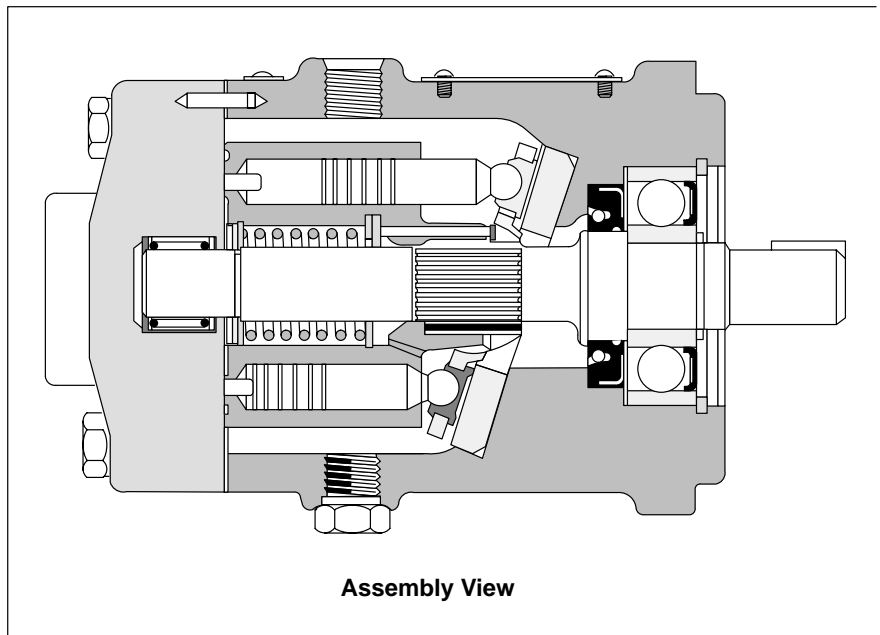
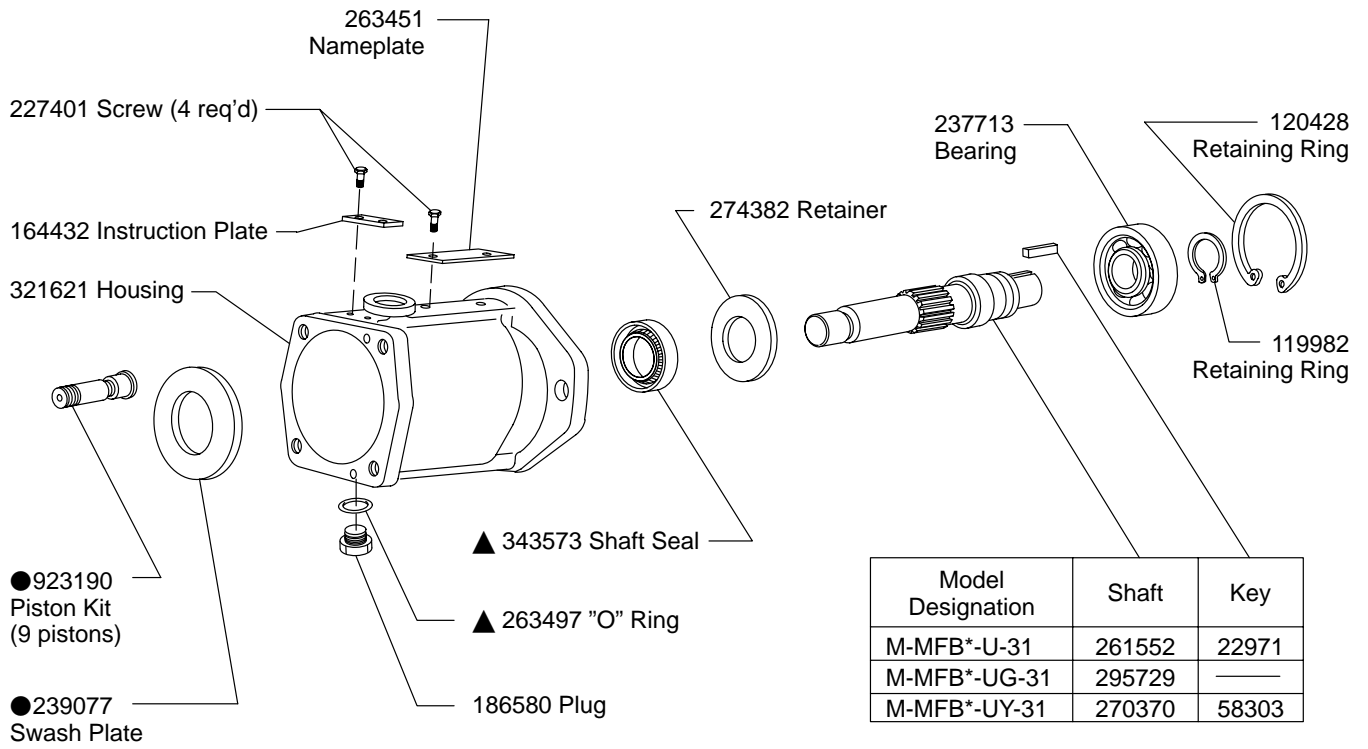

● Included in 922996 Rotating Group Kit

▲ Service all units with F3 Seal Kit 919521

Model Code

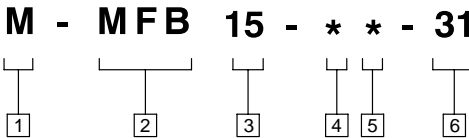

1 Mobile Application

2 Model Series

MFB - Motor, fixed displacement, inline piston type, B series

3 Flow Rating

@1800 RPM

15 - 15 USgpm

4 Shaft Rotation

U - Either direction

5 Shaft Type

Y - Standard (Keyed)

G - Splined

6 Design

For satisfactory service life of these components in industrial applications, use full flow filtration to provide fluid which meets ISO cleanliness code 20/18/15 or cleaner. Selections from Eaton OFP, OFR, and OFRS series are recommended.